

Switch Mode Power Supply

S8VK-G (15/30/60/120/240/480-W Models)

Reliable and Easy Operation-Worldwide Power Supply
Resistant in tough environments
Easy and fast installation
The most compact class on the market

- Universal input for worldwide applications: 100 to 240 VAC (85 to 264 VAC)
- DC input can be available: 90 to 350 VDC
- Possible for 2-phase input usage.
- Wide operation temperature range: -40 to 70 °C
- Power Boost function at 120%
- Safety standards:
 UL508/62368-1, CSA C22.2 No. 107.1/62368-1
 EN50178, EN62368-1.
 Lloyd's standards, EN60204-1 PELV
 Safety of Power Transformers: EN61558-2-16
- 15-W,30-W, and 60-W models conform to
 UL Class 2 output Standards
- EMS: EN 61204-3
 EMI: EN 61204-3 Class B
- Five years Warranty



Refer to *Safety Precautions for All Power Supplies and Safety Precautions* on page 17.

Related Products

Noise Filter
S8V-NF



Note: Refer to the S8V-NF Datasheet (Cat. No. T212) for details.

DC Electronic Circuit Protector
S8V-CP



Note: Refer to the S8V-CP Datasheet (Cat. No. T226-E1) for details.

S8VK-G

Model Number Structure

Model Number Legend

Note: Not all combinations are possible. Refer to *List of Models* in *Ordering Information*, below.

S8VK- **-**

1 2 3 4

1. Input voltage type

G: Single phase

2. Power Ratings

015: 15 W
030: 30 W
060: 60 W
120: 120 W
240: 240 W
480: 480 W

3. Output voltage (VDC)

05: 5 V
12: 12 V
24: 24 V
48: 48 V

4. Option

None: Standard model
400: Coating

Ordering Information

Note: For details on normal stock models, contact your nearest OMRON representative.

| Power ratings | Input voltage | Output Voltage (VDC) | Output current | Boost Current | Model number |
|---------------|---|----------------------|----------------|--------------------|--------------------|
| 15 W | Single phase 100 to 240 VAC 90 to 350 VDC | 5 V | 3 A | 3.6 A | S8VK-G01505 |
| | | 12 V | 1.2 A | 1.44 A | S8VK-G01512 |
| | | 24 V | 0.65 A | 0.78 A | S8VK-G01524 |
| 30 W | | 5 V | 5 A | 6 A | S8VK-G03005 |
| | | 12 V | 2.5 A | 3 A | S8VK-G03012 |
| | | 24 V | 1.3 A | 1.56 A | S8VK-G03024 |
| 60 W | | 12 V | 4.5 A | 5.4 A | S8VK-G06012 |
| | | 24 V | 2.5 A | 3 A | S8VK-G06024 |
| 120 W | | 24 V | 5 A | 6 A | S8VK-G12024 |
| 240 W | | 24 V | 10 A | 12 A | S8VK-G24024 |
| | | 48 V | 5 A | 6 A | S8VK-G24048 |
| 480 W | | 24 V | 20 A | 24 A | S8VK-G48024 |
| | 48 V | 10 A | 12 A | S8VK-G48048 | |

Specifications

Ratings, Characteristics, and Functions

| Item | Power rating Output voltage (VDC) | 15 W | | | 30 W | | | |
|--|--------------------------------------|--|---|--------------------------------------|--|--------------------------------------|--------------------------------------|--------------------------------------|
| | | 5 V | 12 V | 24 V | 5 V | 12 V | 24 V | |
| Efficiency | 230 VAC input *6 | 77% typ. | 77% typ. | 80% typ. | 79% typ. | 82% typ. | 86% typ. | |
| Input | Voltage range *1 | Single-phase, 85 to 264 VAC, 90 to 350 VDC *10 | | | | | | |
| | Frequency *1 | 50/60 Hz (47 to 450 Hz) | | | | | | |
| | Current | 115 VAC input *6 | 0.32 A typ. | 0.3 A typ. | 0.31 A typ. | 0.5 A typ. | 0.57 A typ. | 0.58 A typ. |
| | | 230 VAC input *6 | 0.2 A typ. | 0.21 A typ. | 0.2 A typ. | 0.32 A typ. | 0.37 A typ. | 0.36 A typ. |
| | Power factor | 230 VAC input, 100% load | 0.42 min. | | | 0.43 min. | 0.42 min. | |
| | Leakage current | 115 VAC input | 0.14 mA typ. | | | 0.13 mA typ. | | |
| | | 230 VAC input | 0.25 mA typ. | | | 0.24 mA typ. | | |
| Inrush current *2 (for a cold start at 25°C) | 115 VAC input | 16 A typ. | | | 16 A typ. | | | |
| | 230 VAC input | 32 A typ. | | | 32 A typ. | | | |
| Output | Rated output current | 3 A | 1.2 A | 0.65 A | 5 A | 2.5 A | 1.3 A | |
| | Boost current | 3.6 A | 1.44 A | 0.78 A | 6 A | 3 A | 1.56 A | |
| | Voltage adjustment range *3 | -10% to 15% (with V.ADJ) (guaranteed) | | | | | | |
| | Ripple & Noise voltage *4 | 100 to 240 VAC input, 100% load *6 | 60 mVp-p max. at 20 MHz of bandwidth | 50 mVp-p max. at 20 MHz of bandwidth | 30 mVp-p max. at 20 MHz of bandwidth | 30 mVp-p max. at 20 MHz of bandwidth | 30 mVp-p max. at 20 MHz of bandwidth | 30 mVp-p max. at 20 MHz of bandwidth |
| | | Input variation influence *8 | 0.4% max. | | | 0.4% max. | | |
| | Load variation influence *7 | 0.8% max. | | | 0.8% max. | | | |
| | Temperature variation influence | 115 to 230 VAC input | 0.05%/°C max. | | | 0.05%/°C max. | | |
| | Start up time *2 | 115 VAC input *6 | 530 ms typ. | 520 ms typ. | 580 ms typ. | 550 ms typ. | 550 ms typ. | 600 ms typ. |
| | | 230 VAC input *6 | 330 ms typ. | 400 ms typ. | 400 ms typ. | 430 ms typ. | 490 ms typ. | 480 ms typ. |
| | Hold time *2 | 115 VAC input *6 | 28 ms typ. | 29 ms typ. | 32 ms typ. | 33 ms typ. | 36 ms typ. | 23 ms typ. |
| | | 230 VAC input *6 | 134 ms typ. | 138 ms typ. | 134 ms typ. | 177 ms typ. | 170 ms typ. | 154 ms typ. |
| Additional functions | Overload protection | Yes, automatic reset | | | Yes, automatic reset | | | |
| | Overvoltage protection *5 | Yes, 130% or higher of rated output voltage, power shut off (shut off the input voltage and turn on the input again) | | | | | | |
| | Series operation | Yes (For up to two Power Supplies, external diodes are required.) | | | | | | |
| | Parallel operation | Yes (Refer to <i>Safety Precautions</i>) (For up to two Power Supplies) | | | | | | |
| | Output indicator | Yes (LED: Green), lighting from 80% to 90% or more of rated voltage | | | | | | |
| Insulation | Withstand voltage | 3.0 kVAC for 1 min. (between all input terminals and output terminals), current cutoff 20 mA | | | 2.0 kVAC for 1 min. (between all input terminals and PE terminals), current cutoff 20 mA | | | |
| | | 1.0 kVAC for 1 min. (between all output terminals and PE terminals), current cutoff 20 mA | | | | | | |
| | | 100 MΩ min. (between all output terminals and all input terminals/PE terminals) at 500 VDC | | | | | | |
| Environment | Ambient operating temperature *12 | -40 to 70°C (Derating is required according to the temperature. Refer to <i>Engineering Data</i>) (with no condensation or icing) | | | | | | |
| | Storage temperature | -40 to 85°C (with no condensation or icing) | | | | | | |
| | Ambient operating humidity | 0% to 95% (Storage humidity: 0% to 95%) | | | | | | |
| | Vibration resistance | 10 to 55 Hz, 0.375 mm half amplitude for 2 h each in X, Y, and Z directions | | | | | | |
| | Shock resistance | 150 m/s ² , 3 times each in ±X, ±Y, and ±Z directions | | | | | | |
| Reliability | MTBF | 135,000 hrs min. | | | | | | |
| | Life expectancy *9 | 10 years min. | | | | | | |
| Construction | Weight | 150 g max. | | | 195 g max. | | | |
| | Cooling fan | No | | | | | | |
| | Degree of protection | IP20 by EN/IEC 60529 | | | | | | |
| Standards | Harmonic current emissions | | Conforms to EN 61000-3-2 | | | | | |
| | EMI | Conducted Emissions | Conforms to EN 61204-3 Class B, EN 55011 Class B | | | | | |
| | | Radiated Emissions | Conforms to EN 61204-3 Class B, EN 55011 Class B | | | | | |
| | EMS | | Conforms to EN 61204-3 high severity levels | | | | | |
| | Approved Standards | | UL Listed: UL 508 (Listing, Class2 Output: Per UL 1310) | | | | | |
| | | | UL UR: UL 62368-1 (Recognition) | | | | | |
| | | | cUL: CSA C22.2 No. 107.1 (Class2 Output: Per CSA C22.2 No.223) cUR: CSA C22.2 No.62368-1 EN/VDE: EN 50178, EN 62368-1 | | | | | |
| | Conformed Standards | | PELV (EN 60204-1, EN 50178) | | | | | |
| | | | EN 61558-2-16 | | | | | |
| | | | EAC (TR CU 004 / 2011, TR CU 020 / 2011) RCM (EN61000-6-4) | | | | | |
| | Marine Standards | | Lloyd's register *10 *11 | | | | | |
| SEMI | | Conforms to F47-0706 (200 to 240 VAC input) | | | | | | |

- *1. Do not use an inverter output for the Power Supply. Inverters with an output frequency of 50/60 Hz are available, but the rise in the internal temperature of the Power Supply may result in ignition or burning.
- *2. For a cold start at 25°C. Refer to *Engineering Data* on page 9 to 11 for details.
- *3. If the output voltage adjuster (V. ADJ) is turned, the voltage will increase by more than +15% of the voltage adjustment range. When adjusting the output voltage, confirm the actual output voltage from the Power Supply and be sure that the load is not damaged.
- *4. A characteristic when the ambient operating temperature is between -25 to 70°C.
- *5. Refer to *Overvoltage Protection* on page 10 for the time when input voltage shuts off and input turns on again.
- *6. The value is when both rated output voltage and rated output current are satisfied.
- *7. 100 to 240 VAC input, in the range of 0 A to the rated output current
- *8. This is the maximum variation in the output voltage when the input voltage is gradually changed within the allowable input voltage range at the rated output voltage and rated output current.
- *9. Refer to *Recommended Replacement Periods and Periodic Replacement for Preventive Maintenance* on page 23 for details.
- *10. Safety Standards for a DC Input
The following safety standards apply to a DC input: UL 62368-1, cUR (CSA C22.2 No. 62368-1), EN 50178, EN 62368-1, and Lloyd's.
- For a DC input, safety is ensured by an external fuse.
Select an external fuse that meets the following conditions.
S8VK-G015□□: 350 VDC min, 3 A
S8VK-G030□□: 350 VDC min, 4 A
- *11. Clamp filter "ZCAT2035-0930" manufactured by TDK Corporation. or equivalent should be installed in the cable connected to the input - output terminals of S8VK-G series.
Noise filter "FN2080-10-06" manufactured by SCHAFFNER Corporation. or equivalent should be connected to the Input terminals of S8VK-G series.
- *12. At -40 to -25°C, time will be required before the rated output voltage is output after the input voltage is input.
Also, the ripple noise value may exceed the value shown in the above table.

S8VK-G

| Item | Power rating | | 60 W | | 120 W |
|--|-----------------------------------|--|--|-------------|---------------------------------------|
| | Output voltage (VDC) | | 12 V | 24 V | 24 V |
| Efficiency | 230 VAC input *6 | | 85% typ. | 88% typ. | 89% typ. |
| Input | Voltage range *1 | | Single-phase, 85 to 264 VAC, 90 to 350 VDC *10 | | |
| | Frequency *1 | | 50/60 Hz (47 to 450 Hz) | | 50/60 Hz (47 to 63 Hz) |
| | Current | 115 VAC input *6 | 1.0 A typ. | 1.1 A typ. | 1.3 A typ. |
| | | 230 VAC input *6 | 0.6 A typ. | 0.7 A typ. | 0.7 A typ. |
| | Power factor | 230 VAC input, 100% load | 0.46 min. | 0.45 min. | 0.94 min. |
| | Leakage current | 115 VAC input | 0.16 mA typ. | | 0.24 mA typ. |
| | | 230 VAC input | 0.30 mA typ. | | 0.38 mA typ. |
| Inrush current *2 (for a cold start at 25°C) | 115 VAC input | 16 A typ. | | 16 A typ. | |
| | 230 VAC input | 32 A typ. | | 32 A typ. | |
| Output | Rated output current | | 4.5 A | 2.5 A | 5 A |
| | Boost current | | 5.4 A | 3 A | 6 A |
| | Voltage adjustment range *3 | | -10% to 15% (with V. ADJ) (guaranteed) | | |
| | Ripple & Noise | 100 to 240 VAC input, 100% load *6 | 150 mVp-p max. at 20 MHz of bandwidth | | 150 mVp-p max. at 20 MHz of bandwidth |
| | | | 50 mVp-p max. at 20 MHz of bandwidth | | 150 mVp-p max. at 20 MHz of bandwidth |
| | Input variation influence *8 | | 0.4% max. | | 0.4% max. |
| | Load variation influence *7 | | 0.8% max. | | 0.8% max. |
| | Temperature variation influence | 115 to 230 VAC input | 0.05%/°C max. | | 0.05%/°C max. |
| | | | 0.05%/°C max. | | 0.05%/°C max. |
| | Start up time *2 | 115 VAC input *6 | 570 ms typ. | 650 ms typ. | 790 ms typ. |
| 230 VAC input *6 | | 430 ms typ. | 500 ms typ. | 750 ms typ. | |
| Hold time *2 | 115 VAC input *6 | 26 ms typ. | 25 ms typ. | 42 ms typ. | |
| | 230 VAC input *6 | 139 ms typ. | 129 ms typ. | 42 ms typ. | |
| Additional functions | Overload protection | | Yes, automatic reset | | Yes, automatic reset |
| | Overvoltage protection *5 | | Yes, 130% or higher of rated output voltage, power shut off (shut off the input voltage and turn on the input again) | | |
| | Series operation | | Yes (For up to two Power Supplies, external diodes are required.) | | |
| | Parallel operation | | Yes (Refer to <i>Safety Precautions</i>) (For up to two Power Supplies) | | |
| | Output indicator | | Yes (LED: Green), lighting from 80% to 90% or more of rated voltage | | |
| Insulation | Withstand voltage | | 3.0 kVAC for 1 min. (between all input terminals and output terminals), current cutoff 20 mA | | |
| | | | 2.0 kVAC for 1 min. (between all input terminals and PE terminals), current cutoff 20 mA | | |
| | | | 1.0 kVAC for 1 min. (between all output terminals and PE terminals), current cutoff 20 mA | | |
| Insulation resistance | | 100 MΩ min. (between all output terminals and all input terminals/PE terminals) at 500 VDC | | | |
| Environment | Ambient operating temperature *12 | | -40 to 70°C (Derating is required according to the temperature. Refer to <i>Engineering Data</i>) (with no condensation or icing) | | |
| | Storage temperature | | -40 to 85°C (with no condensation or icing) | | |
| | Ambient operating humidity | | 0% to 95% (Storage humidity: 0% to 95%) | | |
| | Vibration resistance | | 10 to 55 Hz, 0.375 mm half amplitude for 2 h each in X, Y, and Z directions | | |
| | Shock resistance | | 150 m/s ² , 3 times each in ±X, ±Y, ±Z directions | | |
| Reliability | MTBF | | 135,000 hrs min. | | |
| | Life expectancy *9 | | 10 years min. | | |
| Construction | Weight | | 260 g max. | | 620 g max. |
| | Cooling fan | | No | | |
| | Degree of protection | | IP20 by EN/IEC 60529 | | |
| Standards | Harmonic current emissions | | Conforms to EN 61000-3-2 | | |
| | EMI | Conducted Emissions | Conforms to EN 61204-3 Class B, EN 55011 Class B | | |
| | | Radiated Emissions | Conforms to EN 61204-3 Class B, EN 55011 Class B | | |
| | EMS | | Conforms to EN 61204-3 high severity levels | | |
| | Approved Standards | | UL Listed: UL 508 (Listing, For 60 W only Class2 Output: Per UL 1310) | | |
| | | | UL UR: UL 62368-1 (Recognition) | | |
| | | | cUL: CSA C22.2 No. 107.1 (For 60 W only Class2 Output: Per CSA C22.2 No. 223) | | |
| | Conformed Standards | | cUR: CSA C22.2 No. 62368-1 | | |
| | | | EN/VDE: EN 50178, EN 62368-1 | | |
| | | | PELV (EN 60204-1, EN 50178) | | |
| Marine Standards | | EN 61558-2-16 | | | |
| | | EAC (TR CU 004 / 2011, TR CU 020 / 2011) | | | |
| | | RCM (EN61000-6-4) | | | |
| SEMI | | Lloyd's register *10 *11 | | | |
| SEMI | | Conforms to F47-0706 (200 to 240 VAC input) | | | |

- *1. Do not use an inverter output for the Power Supply. Inverters with an output frequency of 50/60 Hz are available, but the rise in the internal temperature of the Power Supply may result in ignition or burning.
- *2. For a cold start at 25°C. Refer to *Engineering Data* on page 9 to 11 for details.
- *3. If the output voltage adjuster (V. ADJ) is turned, the voltage will increase by more than +15% of the voltage adjustment range. When adjusting the output voltage, confirm the actual output voltage from the Power Supply and be sure that the load is not damaged.
- *4. A characteristic when the ambient operating temperature is between -25 to 70°C.
- *5. Refer to *Overvoltage Protection* on page 10 for the time when input voltage shuts off and input turns on again.
- *6. The value is when both rated output voltage and rated output current are satisfied.
- *7. 100 to 240 VAC input, in the range of 0 A to the rated output current
- *8. This is the maximum variation in the output voltage when the input voltage is gradually changed within the allowable input voltage range at the rated output voltage and rated output current.
- *9. Refer to *Recommended Replacement Periods and Periodic Replacement for Preventive Maintenance* on page 23 for details.
- *10. Safety Standards for a DC Input
The following safety standards apply to a DC input: UL 62368-1, cUR (CSA C22.2 No. 62368-1), EN 50178, EN 62368-1, and Lloyd's.
- For a DC input, safety is ensured by an external fuse.
Select an external fuse that meets the following conditions.
S8VK-G060□□: 350 VDC min, 6 A
S8VK-G12024: 350 VDC min, 5 A
- *11. Clamp filter "ZCAT2035-0930" manufactured by TDK Corporation. or equivalent should be installed in the cable connected to the input - output terminals of S8VK-G series.
Noise filter "FN2080-10-06" manufactured by SCHAFFNER Corporation. or equivalent should be connected to the Input terminals of S8VK-G series.
- *12. At -40 to -25°C, time will be required before the rated output voltage is output after the input voltage is input.
Also, the ripple noise value may exceed the value shown in the above table.

| Item | Power rating Output voltage (VDC) | 240 W | | 480 W | | |
|--|--|---|--|--|--|--|
| | | 24 V | 48 V | 24 V | 48 V | |
| Efficiency | 230 VAC input *6 | 92% typ. | | 93% typ. | | |
| Input | Voltage range *1 | Single-phase, 85 to 264 VAC, 90 to 350 VDC *10 | | | | |
| | Frequency *1 | 50/60 Hz (47 to 63 Hz) | | | | |
| | Current | 115 VAC input *6 | 2.4 A typ. | | 4.7 A typ. | |
| | | 230 VAC input *6 | 1.3 A typ. | | 2.3 A typ. | |
| | Power factor | 230 VAC input, 100% load | 0.9 min. | | 0.97 min. | |
| | Leakage current | 115 VAC input | 0.23 mA typ. | | 0.3 mA typ. | |
| | | 230 VAC input | 0.33 mA typ. | | 0.49 mA typ. | |
| Inrush current *2 (for a cold start at 25°C) | 115 VAC input | 16 A typ. | | 16 A typ. | | |
| | 230 VAC input | 32 A typ. | | 32 A typ. | | |
| Output | Rated output current | 10 A | 5 A | 20 A | 10 A | |
| | Boost current | 12 A | 6 A | 24 A | 12 A | |
| | Voltage adjustment range *3 | -10% to 15% (with V.ADJ) (guaranteed) | | | | |
| | Ripple & Noise voltage *4 | 100 to 240 VAC input, 100% load *6 | 180 mVp-p max. at 20 MHz of bandwidth | 350 mVp-p max. at 20 MHz of bandwidth | 230 mVp-p max. at 20 MHz of bandwidth | 470 mVp-p max. at 20 MHz of bandwidth |
| | Input variation influence *8 | 0.4% max. | | | | |
| | Load variation influence *7 | 0.8% max. | | | | |
| | Temperature variation influence | 115 to 230 VAC input | 0.05%/°C max. | | | |
| | Start up time *2 | 115 VAC input *6 | 250 ms typ. | 290 ms typ. | 380 ms typ. | 380 ms typ. |
| | | 230 VAC input *6 | 250 ms typ. | 290 ms typ. | 260 ms typ. | 260 ms typ. |
| | Hold time *2 | 115 VAC input *6 | 44 ms typ. | 43 ms typ. | 40 ms typ. | 40 ms typ. |
| | | 230 VAC input *6 | 44 ms typ. | | 50 ms typ. | 50 ms typ. |
| Additional functions | Overload protection | Yes, automatic reset | | | Yes, automatic reset | |
| | Overvoltage protection *5 | Yes, 130% or higher of rated output voltage, power shut off (shut off the input voltage and turn on the input again) | | | | |
| | Series operation | Yes (For up to two Power Supplies, external diodes are required.) | | | | |
| | Parallel operation | Yes (Refer to <i>Safety Precautions</i>) (For up to two Power Supplies) | | | | |
| | Output indicator | Yes (LED: Green), lighting from 80% to 90% or more of rated voltage | | | | |
| Insulation | Withstand voltage | 3.0 kVAC for 1 min. (between all input terminals and output terminals), current cutoff 20 mA | | | | |
| | | 2.0 kVAC for 1 min. (between all input terminals and PE terminals), current cutoff 20 mA | | | | |
| | | 1.0 kVAC for 1 min. (between all output terminals and PE terminals), current cutoff 20 mA | | | | |
| Insulation resistance | 100 MΩ min. (between all output terminals and all input terminals/PE terminals) at 500 VDC | | | | | |
| Environment | Ambient operating temperature *12 | -40 to 70 °C (Derating is required according to the temperature. Refer to <i>Engineering Data</i>) (with no condensation or icing) | | | | |
| | Storage temperature | -40 to 85°C (with no condensation or icing) | | | | |
| | Ambient operating humidity | 0% to 95% (Storage humidity: 0% to 95%) | | | | |
| | Vibration resistance | 10 to 55 Hz, 0.375 mm half amplitude for 2 h each in X, Y, and Z directions | | | | |
| | Shock resistance | 150 m/s ² , 3 times each in ±X, ±Y, ±Z directions | | | | |
| Reliability | MTBF | 135,000 hrs min. | | | | |
| | Life expectancy *9 | 10 years min. | | | | |
| Construction | Weight | 900 g max. | | 1,500 g max. | | |
| | Cooling fan | No | | | | |
| | Degree of protection | IP20 by EN/IEC 60529 | | | | |
| Standards | Harmonic current emissions | | Conforms to EN 61000-3-2 | | | |
| | EMI | Conducted Emissions | Conforms to EN 61204-3 Class B, EN 55011 Class B | | | |
| | | Radiated Emissions | Conforms to EN 61204-3 Class B, EN 55011 Class B | | | |
| | EMS | | Conforms to EN 61204-3 high severity levels | | | |
| | Approved Standards | | UL Listed: UL 508 (Listing) UL UR: UL 62368-1 (Recognition) cUL: CSA C22.2 No.107.1 cUR: CSA C22.2 No.62368-1 EN/VDE: EN 50178, EN 62368-1 | | | |
| | Conformed Standards | | PELV (EN 60204-1, EN 50178) | | | |
| | | | EN 61558-2-16 | | | |
| | | | EAC (TR CU 004 / 2011, TR CU 020 / 2011) RCM (EN61000-6-4) | | | |
| | Marine Standards | | Lloyd's register *10 *11 | | | |
| | SEMI | | Conforms to F47-0706 (200 to 240 VAC input) | | | |

- *1. Do not use an inverter output for the Power Supply. Inverters with an output frequency of 50/60 Hz are available, but the rise in the internal temperature of the Power Supply may result in ignition or burning.
- *2. For a cold start at 25°C. Refer to *Engineering Data* on page 9 to 11 for details.
- *3. If the output voltage adjuster (V. ADJ) is turned, the voltage will increase by more than +15% of the voltage adjustment range. When adjusting the output voltage, confirm the actual output voltage from the Power Supply and be sure that the load is not damaged.
- *4. A characteristic when the ambient operating temperature is between -25 to 70°C.
- *5. Refer to *Overvoltage Protection* on page 10 for the time when input voltage shuts off and input turns on again.
- *6. The value is when both rated output voltage and rated output current are satisfied.
- *7. 100 to 240 VAC input, in the range of 0 A to the rated output current
- *8. This is the maximum variation in the output voltage when the input voltage is gradually changed within the allowable input voltage range at the rated output voltage and rated output current.
- *9. Refer to *Recommended Replacement Periods and Periodic Replacement for Preventive Maintenance* on page 23 for details.
- *10. Safety Standards for a DC Input
The following safety standards apply to a DC input: UL 62368-1, cUR (CSA C22.2 No. 62368-1), EN 50178, EN 62368-1, and Lloyd's.
For a DC input, safety is ensured by an external fuse.
Select an external fuse that meets the following conditions.
S8VK-G240□□: 350 VDC min, 8 A
S8VK-G480□□: 350 VDC min, 12 A
- *11. Clamp filter "ZCAT2035-0930" manufactured by TDK Corporation. or equivalent should be installed in the cable connected to the input - output terminals of S8VK-G series.
Noise filter "FN2080-10-06" manufactured by SCHAFFNER Corporation. or equivalent should be connected to the Input terminals of S8VK-G series.
- *12. At -40 to -25°C, time will be required before the rated output voltage is output after the input voltage is input.
Also, the ripple noise value may exceed the value shown in the above table.

S8VK-G

Connections

Block Diagrams

S8VK-G015□□ (15 W)

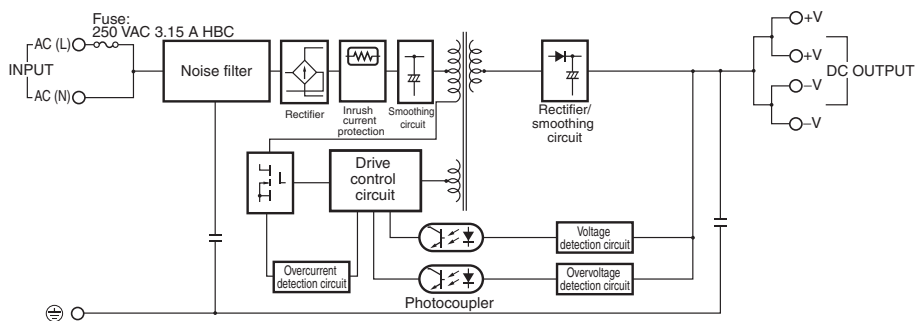

S8VK-G030□□ (30 W)

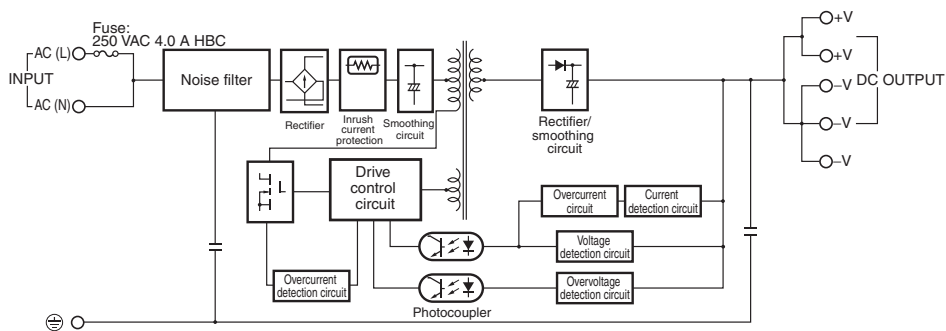

S8VK-G060□□ (60 W)

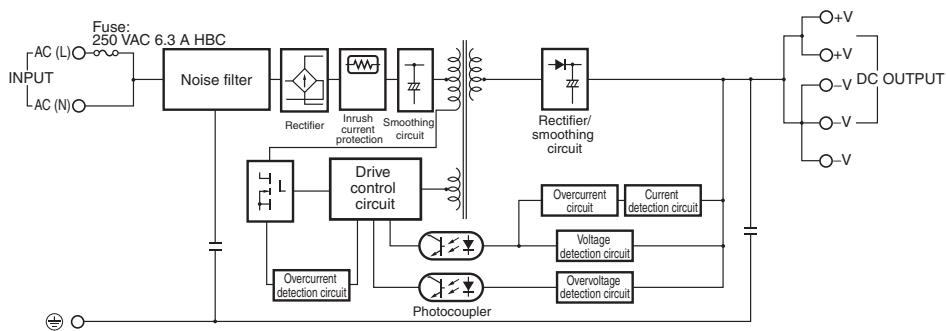

S8VK-G12024 (120 W)

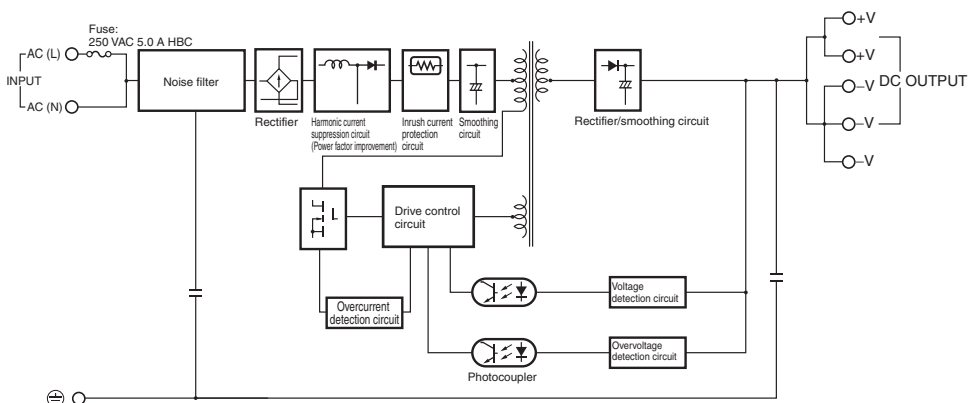

S8VK-G240 (240 W)

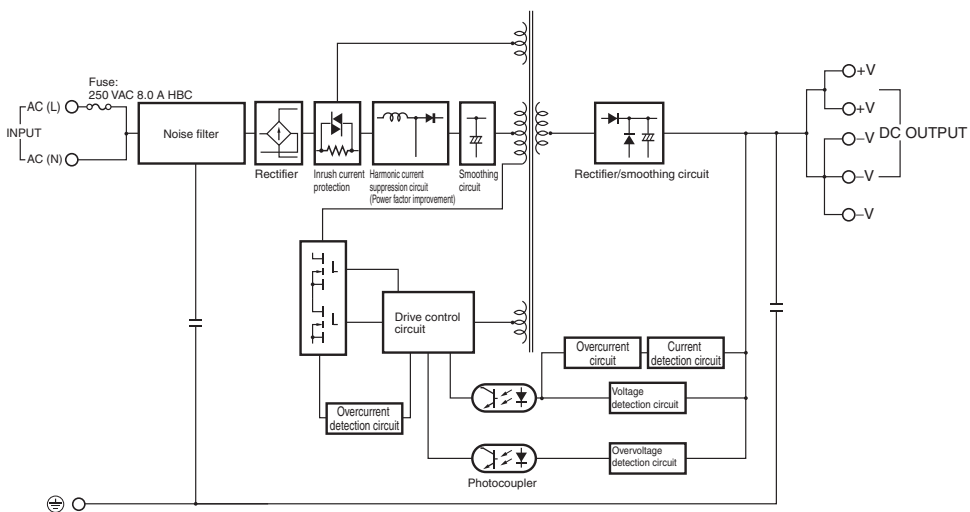

S8VK-G480 (480 W)

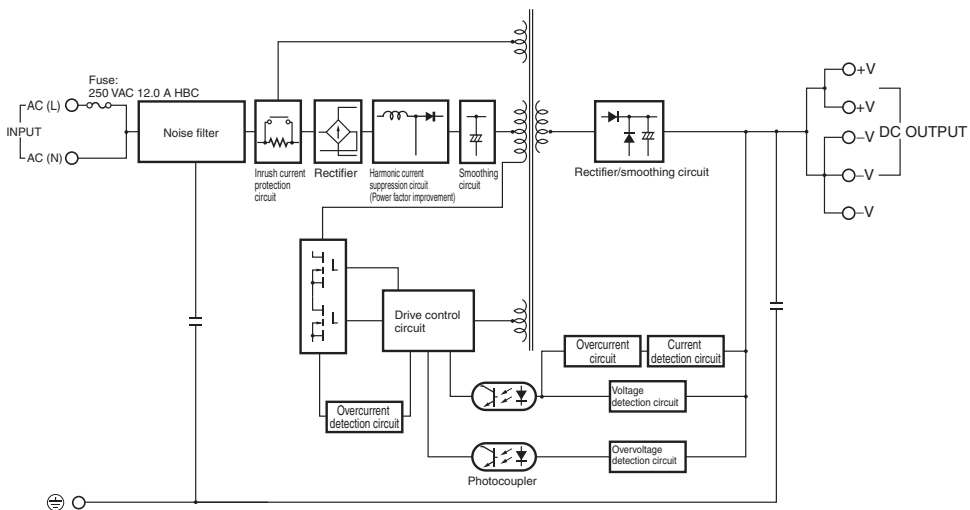

S8VK-G

Construction and Nomenclature

Nomenclature

15-W Models

S8VK-G015□□

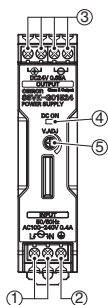

30-W Models

S8VK-G030□□

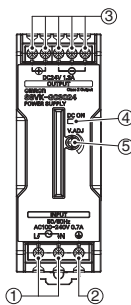

60-W Models

S8VK-G060□□

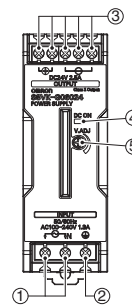

120-W Models

S8VK-G12024

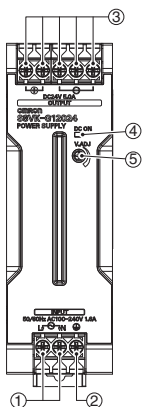

240-W Models

S8VK-G240□□

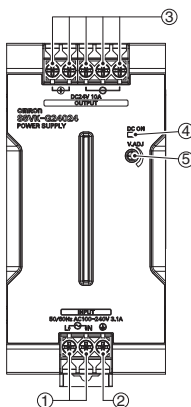

480-W Models

S8VK-G480□□

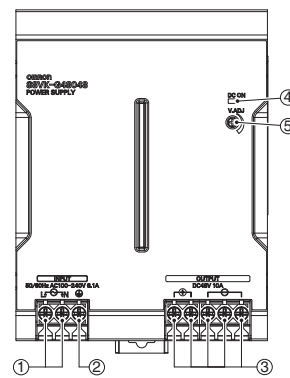

| No. | Name | Function |
|-----|---------------------------------|--|
| 1 | Input terminals (L), (N) | Connect the input lines to these terminals. *1 |
| 2 | Protective Earth terminal (PE) | Connect the ground line to this terminal. *2 |
| 3 | DC Output terminals (-V), (+V) | Connect the load lines to these terminals. |
| 4 | Output indicator (DC ON: Green) | Lights while a direct current (DC) output is ON. |
| 5 | Output voltage adjuster (V.ADJ) | Use to adjust the voltage. |

*1. The fuse is located on the (L) side. It is not user-replaceable. For a DC input, connect the positive voltage to the L terminal.

*2. This is the protective earth terminal specified in the safety standards. Always ground this terminal.

Engineering Data

Derating Curve

15, 30, 240 W (S8VK-G015□□, S8VK-G030□□, S8VK-G240□□)

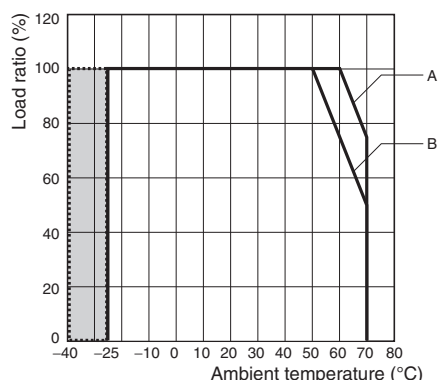

- Note:**
- At less than 90 VAC, the derating is 2.5%/V
 - For a DC power input, reduce the load given in the above derating curve by multiplying the following coefficients.
 S8VK-G015□□: 1.0
 S8VK-G030□□: 0.9
 S8VK-G240□□: 0.8
 - This is the guaranteed value for startup.

- A.** Standard mounting
B. Face-up mounting / Side mounting (15W only)

60 W (S8VK-G060□□)

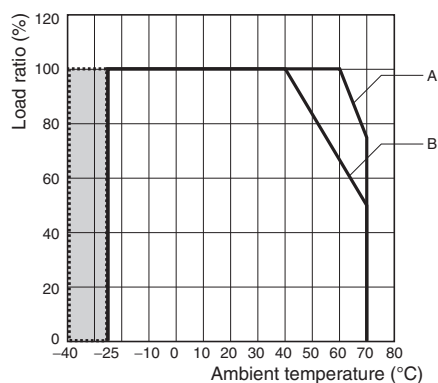

- Note:**
- At less than 90 VAC, the derating is 2.5%/V
 - For a DC power input, reduce the load given in the above derating curve by multiplying the following coefficients.
 S8VK-G060□□: 0.9
 - This is the guaranteed value for startup.

- A.** Standard mounting
B. Face-up mounting

120 W (S8VK-G12024)

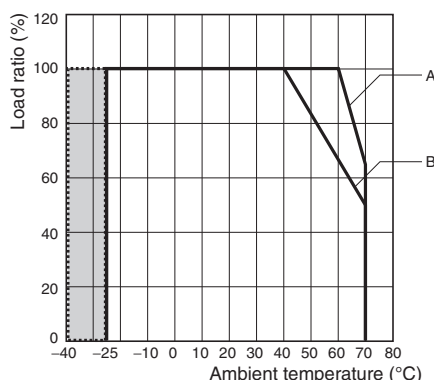

- Note:**
- At less than 90 VAC, the derating is 2.5%/V
 - For a DC power input, reduce the load given in the above derating curve by multiplying the following coefficients.
 S8VK-G12024: 0.9
 - This is the guaranteed value for startup.

- A.** Standard mounting
B. Face-up mounting

480 W (S8VK-G480□□)

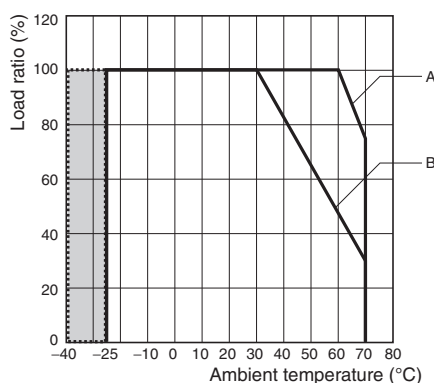

- Note:**
- At less than 90 VAC, the derating is 2.5%/V
 - For a DC power input, reduce the load given in the above derating curve by multiplying the following coefficients.
 S8VK-G480□□: 0.8
 - This is the guaranteed value for startup.

- A.** Standard mounting
B. Face-up mounting

Mounting

(A) Standard (Vertical) mounting (B) Face-up mounting

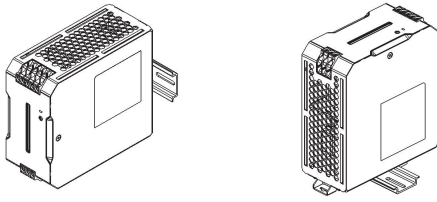

(C) Side mounting only for 15 W

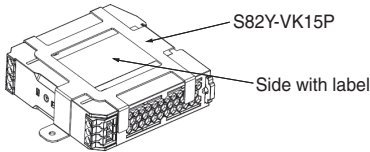

Side mounting is only for S8VK-G015□□. Use a mounting bracket (S82Y-VK15P, sold separately) when the product is mounted horizontally. Heat dissipation will be adversely affected. When the product is mounted facing horizontally, always place the side with label facing upward.

Overload Protection

The load and the power supply are automatically protected from overcurrent damage by this function. Overload protection is activated if the output current rises above 121% of the rated current. When the output current returns within the rated range, overload protection is automatically cleared.

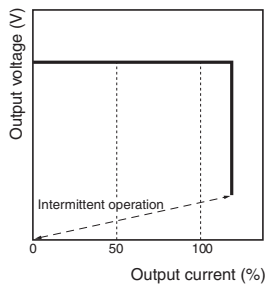

The values shown in the above diagrams are for reference only.

- Note: 1.** Internal parts may occasionally deteriorate or be damaged if a short-circuited or overcurrent state continues during operation.
- 2.** Internal parts may possibly deteriorate or be damaged if the Power Supply is used for applications with frequent inrush current or overloading at the load end. Do not use the Power Supply for such applications.

Overvoltage Protection

Consider the possibility of an overvoltage and design the system so that the load will not be subjected to an excessive voltage even if the feedback circuit in the Power Supply fails. If an excessive voltage that is approximately 130% of the rated voltage or more is output, the output voltage is shut OFF. Reset the input power by turning it OFF for at least three minutes and then turning it back ON again.

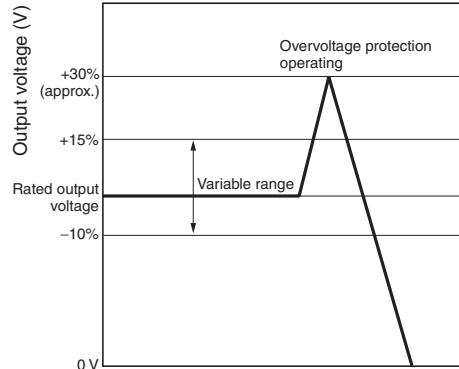

The values shown in the above diagram is for reference only.

Note: Do not turn ON the power again until the cause of the overvoltage has been removed.

Inrush Current, Startup Time, Output Hold Time

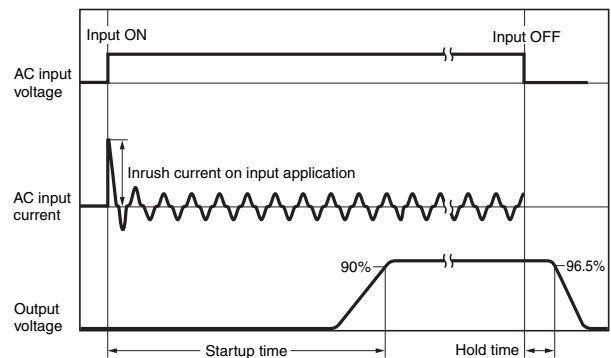

Note: Twice the input current or above will flow during the parallel operation or redundant system. Therefore, check the fusing characteristics of fuses and operating characteristics of breakers making sure that the external fuses will not burn out and the circuit breakers will not be activated by the inrush current.

Two phases application for Single phase models

For All Single phase Models, S8VK-G

Basically OMRON single phase power supply can be used on two-phases of a 3-phase-system when some of conditions satisfy like below.

1. The supplying voltage is below the maximum rated input.
OMRON Power supply allows the input voltage equivalent or less than 240 VAC+10%.
Please confirm the input voltage between two lines if the input voltage satisfies this condition before connecting.
2. The external protector is needed on N input line to secure a safety.
N line has no protection of a fuse internally.
An appropriate fuse or circuit breaker should be connected on N input line like the following.

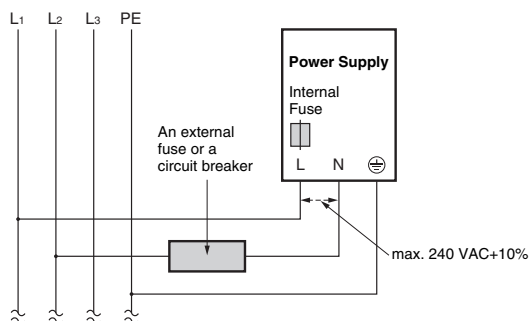

Reference Value

| | Value |
|---------------------------|--|
| Reliability (MTBF) | Single phase model 15 W: 600,000 hrs 30 W: 580,000 hrs 60 W: 590,000 hrs 120 W: 450,000 hrs 240 W: 360,000 hrs 480 W: 230,000 hrs |
| Definition | MTBF stands for Mean Time Between Failures, which is calculated according to the probability of accidental device failures, and indicates reliability of devices. Therefore, it does not necessarily represent a life of the product. |
| Life expectancy | 10 yrs. Min. |
| Definition | The life expectancy indicates average operating hours under the ambient temperature of 40°C and a load rate of 50%. Normally this is determined by the life expectancy of the built-in aluminum electrolytic capacitor. |

S8VK-G

Dimensions

(Unit: mm)

S8VK-G015□□ (15 W)

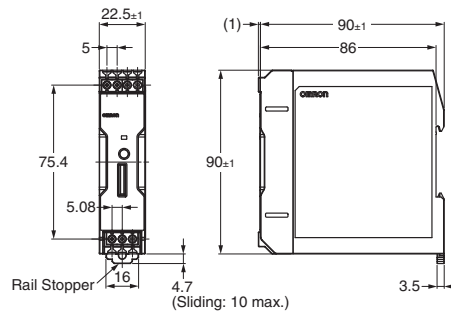

S8VK-G030□□ (30 W)

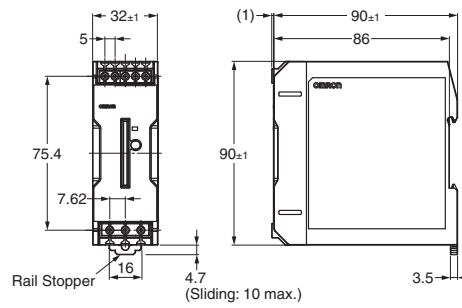

S8VK-G060□□ (60 W)

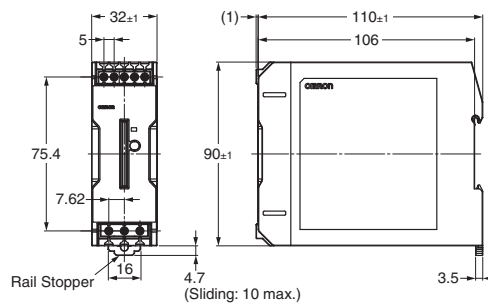

S8VK-G12024 (120 W)

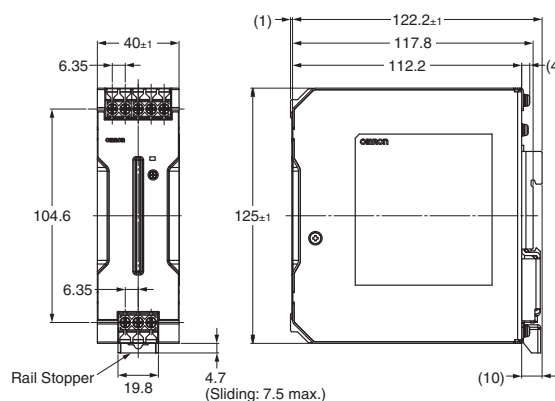

S8VK-G240□□ (240 W)

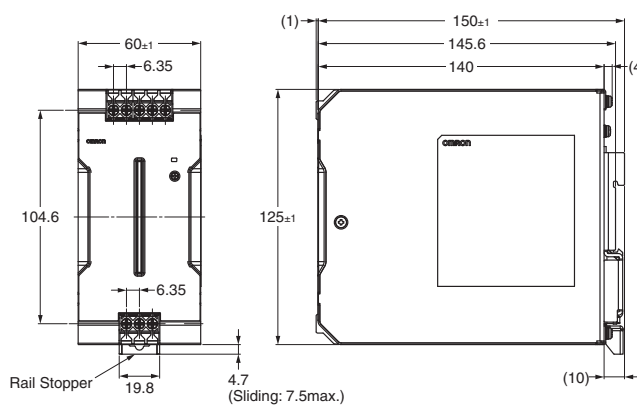

S8VK-G480□□ (480 W)

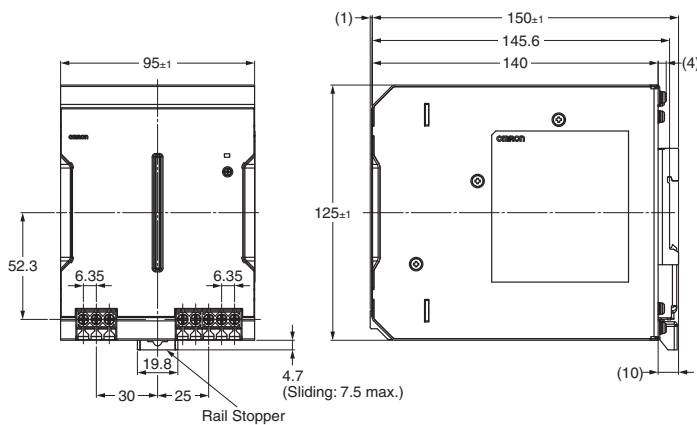

DIN Rail (Order Separately)

Note: All units are in millimeters unless otherwise indicated.

Mounting Rail (Material: Aluminum)

PFP-100N

PFP-50N

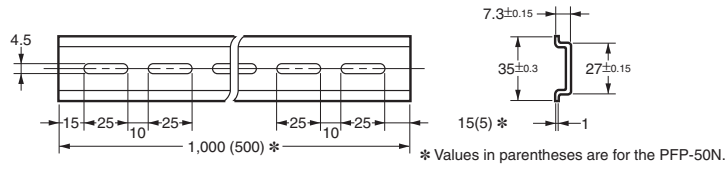
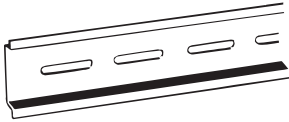

Mounting Rail (Material: Aluminum)

PFP-100N2

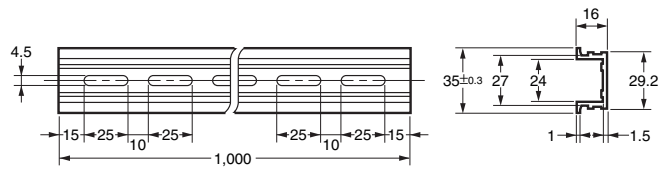
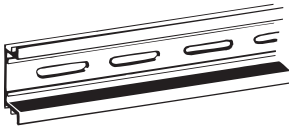

End Plate

PFP-M

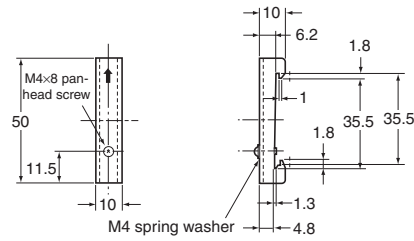
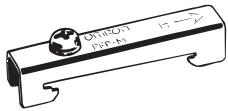

Note: If there is a possibility that the Unit will be subject to vibration or shock, use a steel DIN Rail. Otherwise, metallic filings may result from aluminum abrasion.

Mounting Brackets

| Name | Model |
|--|-------------------|
| Front-mounting bracket (for 15, 30 and 60 W models) | S82Y-VS10F |
| Front-mounting bracket (for 120, 240 and 480 W models) | S82Y-VK10F |
| Side-mounting bracket (for 15 W models) | S82Y-VK15P |
| Side-mounting bracket (for 30 and 60 W models) | S82Y-VS10S |
| Side-mounting bracket (for 120 W models) | S82Y-VK10S |
| Side-mounting bracket (for 240 W models) | S82Y-VK20S |

Note: Be sure to use the accessory screws.

Mounting screw tightening torque (recommended): 4.43 to 5.31 lb-in (0.5 to 0.6 N·m)

| Type | Model | Dimensions | Appearance |
|---|-------------------|------------|---|
| Front-mounting bracket (For 15, 30 and 60 W models) | S82Y-VS10F | | |
| Front-mounting bracket (For 120, 240 and 480 W models) | S82Y-VK10F | | <p>(For 120 W types) (For 240 W types)</p> |
| Side-mounting bracket (For 15 W Models) | S82Y-VK15P | | <p>Right-side mounting</p> |

S8VK-G

| Type | Model | Dimensions | Appearance |
|---|------------|--|---|
| Side-mounting bracket (For 30 and 60 W models) | S82Y-VS10S | <p>Technical drawing of the S82Y-VS10S side-mounting bracket. It shows a top view with dimensions 35 and 64, and a side view with dimensions 80, 55±0.1, 13, and 60±0.1. A hole diameter of 4.5 dia.±0.1 and a thickness of t = 2.0 are also indicated.</p> | <p>Left-side mounting Right-side mounting</p> |
| Side-mounting bracket (For 120 W models) | S82Y-VK10S | <p>Technical drawing of the S82Y-VK10S side-mounting bracket. It shows a top view with dimensions 40 and 49, and a side view with dimensions 73, 50±0.1, 15.5±0.1, 125, 140±0.1, and 150. A hole diameter of 4.5 dia.±0.1 and a thickness of t = 2.0 are also indicated.</p> | <p>Left-side mounting Right-side mounting</p> <p>Left-side mounting (DIN Rail) * Right-side mounting (DIN Rail) *</p> |
| Side-mounting bracket (For 240 W models) | S82Y-VK20S | <p>Technical drawing of the S82Y-VK20S side-mounting bracket. It shows a top view with dimensions 40 and 59, and a side view with dimensions 73, 50±0.1, 15.5±0.1, 125, 140±0.1, and 150. A hole diameter of 4.5 dia.±0.1 and a thickness of t = 2.0 are also indicated.</p> | <p>Left-side mounting Right-side mounting</p> <p>Left-side mounting (DIN Rail) * Right-side mounting (DIN Rail) *</p> |





* You can mount the side of the Power Supply to a DIN Rail by removing the DIN Rail Back-mounting Bracket and then attaching a Side-mounting Bracket to the Power Supply.

Safety Precautions

Warning Indications

| | |
|--|---|
|  CAUTION | Indicates a potentially hazardous situation which, if not avoided, may result in minor or moderate injury or in property damage. |
| Precautions for Safe Use | Supplementary comments on what to do or avoid doing, to use the product safely. |
| Precautions for Correct Use | Supplementary comments on what to do or avoid doing, to prevent failure to operate, malfunction or undesirable effect on product performance. |

Meaning of Product Safety Symbols

| | |
|--|--|
|  | Used to warn of the risk of electric shock under specific conditions. |
|  | Used to warn of the risk of minor injury caused by high temperatures. |
|  | Used for general mandatory action precautions for which there is no specified symbol. |
|  | Use to indicate prohibition when there is a risk of minor injury from electrical shock or other source if the product is disassembled. |

CAUTION

Minor electric shock, fire, or Product failure may occasionally occur. Do not disassemble, modify, or repair the Product or touch the interior of the Product.



Minor burns may occasionally occur. Do not touch the Product while power is being supplied or immediately after power is turned OFF.



Fire may occasionally occur. Tighten terminal screws to the specified torque (0.5 to 0.6 N·m).



Minor injury due to electric shock may occasionally occur. Do not touch the terminals while power is being supplied. Always close the terminal cover after wiring.



Minor electric shock, fire, or Product failure may occasionally occur. Do not allow any pieces of metal or conductors or any clippings or cuttings resulting from installation work to enter the Product.



Precautions for Safe Use

Wiring

- Connect the ground completely. A protective earthing terminal stipulated in safety standards is used. Electric shock or malfunction may occur if the ground is not connected completely.
- Minor fire may possibly occur. Ensure that input and output terminals are wired correctly.
- Do not apply more than 75-N force to the terminal block when tightening it.
- Be sure to remove the sheet covering the Product for machining before power-ON so that it does not interfere with heat dissipation.
- Use the following material for the wires to be connected to the S8VK-G to prevent smoking or ignition caused by abnormal loads.

Recommended Wire Type/Cross-sectional Area and Stripping Length

| Model | INPUT | | OUTPUT | | PE | | Wire Stripping Length |
|-------------|---------------------|---|---------------------|---|---------------------|--|-----------------------|
| | American Wire Gauge | Solid Wire /Stranded Wire | American Wire Gauge | Solid Wire /Stranded Wire | American Wire Gauge | Solid Wire /Stranded Wire | |
| S8VK-G01505 | AWG24 to 12 | 0.25 to 4 mm ² /0.25 to 2.5 mm ² | AWG20 to 12 | 0.5 to 4 mm ² /0.5 to 2.5 mm ² | AWG14 to 12 | 2.5 to 4 mm ² / 2.5 to 4 mm ² | 8 to 10 mm |
| S8VK-G01512 | | | AWG22 to 12 | 0.35 to 4 mm ² /0.35 to 2.5 mm ² | | | |
| S8VK-G01524 | | | AWG24 to 12 | 0.25 to 4 mm ² /0.25 to 2.5 mm ² | | | |
| S8VK-G03005 | AWG24 to 12 | 0.25 to 4 mm ² /0.25 to 2.5 mm ² | AWG18 to 12 | 0.75 to 4 mm ² /0.75 to 2.5 mm ² | | | |
| S8VK-G03012 | | | AWG20 to 12 | 0.5 to 4 mm ² /0.5 to 2.5 mm ² | | | |
| S8VK-G03024 | | | AWG22 to 12 | 0.35 to 4 mm ² /0.35 to 2.5 mm ² | | | |
| S8VK-G06012 | AWG22 to 12 | 0.35 to 4 mm ² /0.35 to 2.5 mm ² | AWG18 to 12 | 0.75 to 4 mm ² /0.75 to 2.5 mm ² | | | |
| S8VK-G06024 | | | AWG20 to 12 | 0.5 to 4 mm ² /0.5 to 2.5 mm ² | | | |
| S8VK-G12024 | AWG22 to 10 | 0.35 to 6 mm ² /0.35 to 4 mm ² | AWG18 to 10 | 0.75 to 6 mm ² /0.75 to 4 mm ² | | | |
| S8VK-G24024 | AWG20 to 10 | 0.5 to 6 mm ² /0.5 to 4 mm ² | AWG14 to 10 | 2.5 to 6 mm ² /2.5 to 4 mm ² | | | |
| S8VK-G24048 | | | AWG18 to 10 | 0.75 to 6 mm ² /0.75 to 4 mm ² | | | |
| S8VK-G48024 | AWG16 to 10 | 1.5 to 6 mm ² /1.5 to 4 mm ² | AWG12 to 10 | 4 to 6 mm ² /4 mm ² | | | |
| S8VK-G48048 | | | AWG14 to 10 | 2.5 to 6 mm ² /2.5 to 4 mm ² | | | |

- The wire insertion hole, and applicable screwdriver of the terminal block are as follows.

| Model | Wire Insertion Hole (Refer to the diagram on the right) | | Applicable Screwdriver | | |
|-------------|--|-----|------------------------|-----------------|-------------|
| | W | L | No. | Driver Diameter | Length |
| S8VK-G01505 | 2.7 | 2.9 | #1 | 3.5 mm max. | 4.5 mm min. |
| S8VK-G01512 | | | | | |
| S8VK-G01524 | | | | | |
| S8VK-G03005 | | | | | |
| S8VK-G03012 | | | | | |
| S8VK-G03024 | | | | | |
| S8VK-G06012 | | | | | |
| S8VK-G06024 | 2.9 | | #2 | 4.9 mm max. | 10 mm min. |
| S8VK-G12024 | | | | | |
| S8VK-G24024 | | | | | |
| S8VK-G24048 | | | | | |
| S8VK-G48024 | | | | | |
| S8VK-G48048 | | | | | |



Recommended ferrules and Crimp Tools

| Applicable wire | | Ferrules Conduct length (mm) | Stripping length (mm) (Ferrules used) | Recommended ferrules | | |
|------------------------|-------|------------------------------------|--|----------------------------|-----------------------|--------------------|
| (mm ²) | (AWG) | | | Phoenix Contact product | Weidmuller product | Nichifu product |
| 0.25 | 24 | 8 | 10 | AI 0.25-8 | H0.25/12 | --- |
| | | 10 | 12 | AI 0.25-10 | --- | --- |
| 0.34 | 22 | 8 | 10 | AI 0.34-8 | H0.34/12 | TE0.5-8 |
| | | 10 | 12 | AI 0.34-10 | --- | TE0.5-10 |
| 0.50 | 20 | 8 | 10 | AI 0.5-8 | H0.5/14 | TE0.75-8 |
| | | 10 | 12 | AI 0.5-10 | --- | TE0.75-10 |
| 0.75 | 18 | 8 | 10 | AI 0.75-8 | H0.75/14 | TE1.0-8 |
| | | 10 | 12 | AI 0.75-10 | --- | TE1.0-10 |
| 1.5 | 16 | 8 | 10 | AI 1.5-8 | H1.5/14 | TE1.5-8 |
| | | 10 | 12 | AI 1.5-10 | --- | TE1.5-10 |
| 2.5 | 14 | 8 | 10 | AI 2.5-8 | H2.5/15 | TE2.5-8 |
| | | 10 | 12 | AI 2.5-10 | --- | TE2.5-10 |
| 3.5 | 12 | 10 | 12 | AI 4-10 | H4.0/18 | TE4.0-10 |
| 6 | 10 | 12 | 16 | AI 6-12 | H6.0/20 | TE6.0-12 |
| Recommended crimp tool | | | | CRIMPFOX10S | | |

Note: 1. Make sure that the outer diameter of the wire is smaller than the inner diameter of the insulating sleeve of the recommended ferrule.
2. Make sure that the ferrule processing dimensions conform to the following figure.

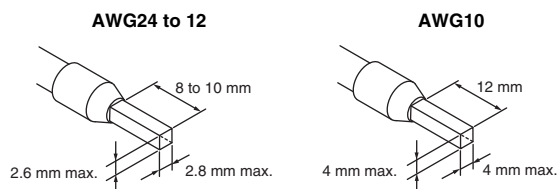

Installation Environment

- Do not use the Power Supply in locations subject to shocks or vibrations. In particular, install the Power Supply as far away as possible from contactors or other devices that are a vibration source. For usage onboard a ship, always attach an End Plate (PFP-M) to both sides of the Power Supply to hold the Power Supply in place.
- Install the Power Supply well away from any sources of strong, high-frequency noise and surge.

Operating Life

- The life of a Power Supply is determined by the life of the electrolytic capacitors used inside. Here, Arrhenius Law applies, i.e., the life will be cut in half for each rise of 10°C or the life will be doubled for each drop of 10°C. The life of the Power Supply can thus be increased by reducing its internal temperature.

Ambient Operating and Storage Environments

- Store the Power Supply at a temperature of -40 to 85°C and a humidity of 0% to 95%.
- Do not use the Power Supply in areas outside the derating curve otherwise, internal parts may occasionally deteriorate or be damaged.
- Use the Power Supply at a humidity of 0% to 95%.
- Do not use the Power Supply in locations subject to direct sunlight.
- Do not use the Power Supply in locations where liquids, foreign matter, or corrosive gases may enter the interior of Products.

Mounting

- Take adequate measures to ensure proper heat dissipation to increase the long-term reliability of the Product. Be sure to allow convection in the atmosphere around devices when mounting. Do not use in locations where the ambient temperature exceeds the range of the derating curve.
- When cutting out holes for mounting, make sure that cuttings do not enter the interior of the Products.

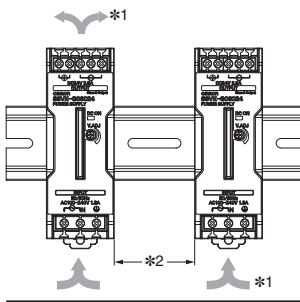

- *1. Convection of air
- *2. 20 mm min.

- Improper mounting will interfere with heat dissipation and may occasionally result in deterioration or damage of internal parts. Use the Product within the derating curve for the mounting direction that is used.
- Use a mounting bracket when the Product is mounted facing horizontally.
- Heat dissipation will be adversely affected. When the Product is mounted facing horizontally, always place the side with the label facing upward.

DIN Rail Mounting

To mount the Block on a DIN Rail, hook portion (A) of the Block onto the rail and press the Block in direction (B).

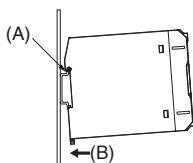

To dismount the Block, pull down portion (C) with a flat-blade screwdriver and pull out the Block.

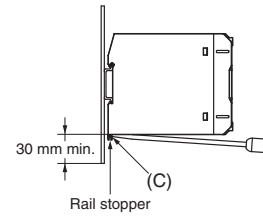

Power Boost Function

For All Models

Power Boost is a function that can output the temporary repeated boost current larger than the rated current.

However, it should meet the following four Boost current conditions.

1. Time that the boost current flows: t_1
2. The maximum value of the boost current: I_p
3. The average output current: I_{ave}
4. The time ratio of the boost current flow: Duty

Note: Boost current conditions

- $t_1 \leq 10$ s
- $I_p \leq$ Rated boost current
- $I_{ave} \leq$ Rated current

$$\text{Duty} = \frac{t_1}{t_1 + t_2} \times 100 [\%] \leq 30\%$$

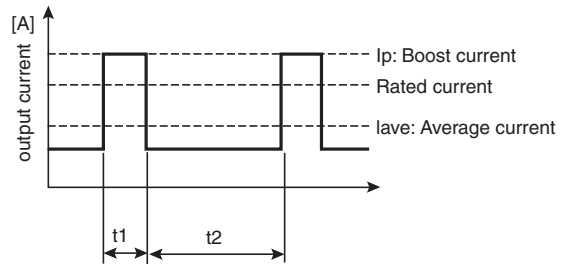

- Do not allow the boost current to continue for more than 10 seconds. Also, do not let the duty cycle exceed the boost current conditions. These conditions may damage the Power supply.
- Ensure that the average current of one cycle of the boost current does not exceed the rated output current. This may damage the Power Supply.
- Lessen the load of the boost load current by adjusting the ambient temperature and the mounting direction.

Overcurrent Protection

- Internal parts may possibly deteriorate or be damaged if a short-circuited or overcurrent state continues during operation.
- Internal parts may possibly deteriorate or be damaged if the Power Supply is used for applications with frequent inrush current or overloading at the load end. Do not use the Power Supply for such applications.
- The DC ON indicator (green) flashes if the overload protection function operates.

Charging a Battery

If you connect a battery as the load, install overcurrent control and overvoltage protection circuits.

Output Voltage Adjuster (V.ADJ)

- The output voltage adjuster (V.ADJ) may possibly be damaged if it is turned with unnecessary force. Do not turn the adjuster with excessive force.
- After completing output voltage adjustment, be sure that the output capacity or output current does not exceed the rated output capacity or rated output current.

Series Operation

Two power supplies can be connected in series.

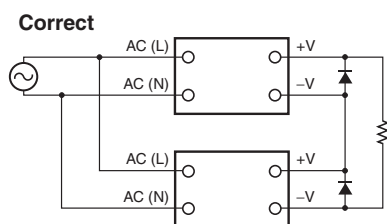

Note: 1. The diode is connected as shown in the figure. If the load is short-circuited, a reverse voltage will be generated inside the Power Supply. If this occurs the Power Supply may possibly deteriorate or be damaged. Always connect a diode as shown in the figure. Select a diode having the following ratings.

| Type | Schottky Barrier diode |
|----------------------------|---|
| Dielectric strength (VRRM) | Twice the rated output voltage or above |
| Forward current (IF) | Twice the rated output current or above |

2. Although Products having different specifications can be connected in series, the current flowing through the load must not exceed the smaller rated output current.

Making Positive/Negative Outputs

- The outputs are floating outputs (i.e., the primary circuits and secondary circuits are separated). You can therefore make positive and negative outputs by using two Power Supplies. You can make positive and negative outputs with any of the models.

If positive and negative outputs are used, connect Power Supplies of the same model as in the following figure. (Combinations with different output capacities or output voltages can be made. However, use the lower of the two maximum rated output currents as the current to the loads.)

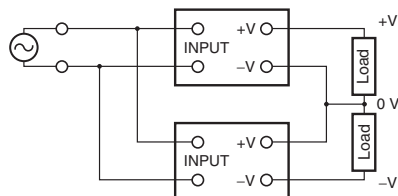

- Depending on the model, internal circuits may be damaged due to startup failure when the power is turned ON if loads such as a servomotor or operational amplifier may operate in series. Therefore, connect bypass diodes (D1, D2) as shown in the following figure.

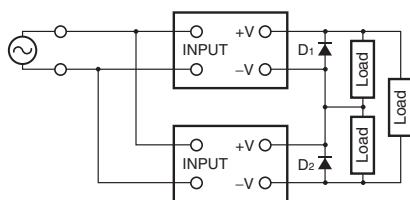

- Use the following information as a guide to the diode type, dielectric strength, and current.

| Type | Schottky Barrier diode |
|----------------------------|---|
| Dielectric strength (VRRM) | Twice the rated output voltage or above |
| Forward current (IF) | Twice the rated output current or above |

Parallel Operation

Parallel operation is used when the output current from one Power Supply is insufficient for the load. Power Supplies are connected in parallel to increase the output current.

The parallel operation of S8VK-G is possible to increase the output power.

However please consider the following notes when the parallel operation must be done.

- The range of ambient temperature for Parallel operation is -25 to 40°C.
- Up to two of the same model can be connected in parallel.
- Adjust the output voltage difference of each Power Supply to 50 mV or less, using the output voltage adjuster (V. ADJ).
- There is no current balancing function for S8VK-G. A high output voltage unit may work at overcurrent state and in this situation, a life of a Power Supply will be extremely short. After adjusting the output voltage, confirm the output current of the two Power Supplies balances.
- Using the parallel operation will not satisfy UL1310 Class2 output.
- For Parallel Operation, to balance the current of the each unit, the length and thickness of each wire connected to the load and each unit must be same as much as possible.
- If you use the 15-W to 240-W S8VK-G in parallel operation, the output voltage may drop by several volts if the load changes rapidly (e.g., if the load starts or is disconnected). If operation becomes unstable, use the S8VK-R as shown in the diagram. Refer to the S8VK-R datasheet (Catalog No.: T059) for S8VK-R specifications and the model number for each capacity.

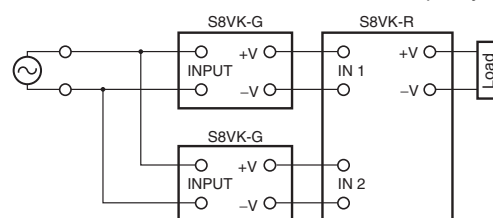

- If you use the 480-W S8VK-G in parallel operation, the output voltage may drop by several volts if the load changes rapidly (e.g., if the load starts or is disconnected). If operation becomes unstable, connect a diode as shown in the diagram.

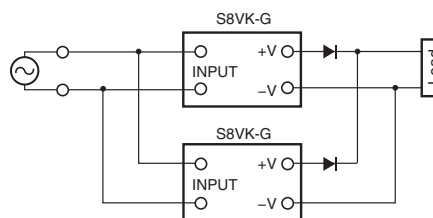

- Use the following information as a guide to the diode type, dielectric strength, and current.

| Type | Schottky Barrier diode |
|----------------------------|---|
| Dielectric strength (VRRM) | Twice the rated output voltage or above |
| Forward current (IF) | Twice the rated output current or above |

Backup Operation

Backup operation is possible if you use two Power Supplies of the same model.

Even if one Power Supply fails, operation can be continued with the other Power Supply.

Make sure that the maximum load does not exceed the capacity of one Power Supply.

For backup operation, connect the S8VK-R as shown in the figure.

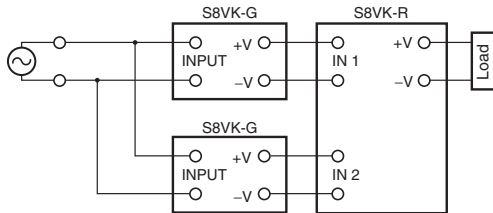

Refer to the S8VK-R datasheet (Catalog No.: T059) for S8VK-R specifications and the model number for each capacity.

In Case There Is No Output Voltage

The possible cause for no output voltage may be that the overcurrent or overvoltage protection has operated. The internal protection may operate if a large amount of surge voltage such as a lightning surge occurs while turning ON the power supply.

In case there is no output voltage, please check the following points before contacting us:

- Checking overload protected status:
Check whether the load is in overload status or is short-circuited.
Remove wires to load when checking.
- Checking overvoltage or internal protection:
Turn the power supply OFF once, and leave it OFF for at least 3 minutes. Then turn it ON again to see if this clears the condition.

Audible Noise at Power ON (120-W, 240-W, and 480-W Models)

A harmonic current suppression circuit is built into the Power Supply. This circuit can create noise when the input is turned ON, but it will last only until the internal circuits stabilize and does not indicate any problem in the Product.

Period and Terms of Warranty

Warranty Period

The Power Supply warranty is valid for a period of Five years from the date of shipment from the factory.

Terms of Warranty

The warranty is valid only for the following operating conditions.

1. Average ambient operating temperature of the Power Supply: 40°C max.
2. Average load rate of 80% max.
3. Mounting method: Standard mounting

Note: The maximum ratings must be within the derating curve.

If the Power Supply fails for reasons attributable to OMRON within the above warranty period, OMRON will repair or replace the faulty part of the Power Supply at the place of purchase or the place where the Power Supply delivered without charge.

This warranty does not cover the following types of failures.

- (1) Failures that result from handling or operation of the Power Supply under conditions or in environments that are not given in this document and not given in any other specifications exchanged between OMRON and the customer
 - (2) Failures that originate in causes other than the delivered product itself
 - (3) Failures caused by disassembly, modification, or repair of the Power Supply by anyone other than OMRON
 - (4) Failures caused by applications or uses for which the Power Supply was not originally intended.
 - (5) Failures caused by factors that could not be anticipated with the scientific or technical knowledge available when the Power Supply was shipped.
 - (6) Failures caused by other causes for which OMRON is not responsible, such as natural disasters and other acts of God.
- This warranty is limited to the individual Power Supply that was delivered and does not cover any secondary, subsequent, or related damages.

Recommended Replacement Periods and Periodic Replacement for Preventive Maintenance

The recommended replacement period for preventive maintenance is greatly influenced by the application environment of the Power Supply. As a guideline, the recommended replacement period is 7 to 10 years.*

S8VK-X is equipped with a replacement time calculation function, and the approximate number of years until replacement based on the ambient temperature and load rate can be checked via indicator (types with indication monitors only) or communication.

To prevent failures or accidents that can be caused by using a Power Supply beyond its service life, we recommend that you replace the Power Supply as early as possible within the recommended replacement period.

However, bear in mind that the recommended replacement period is for reference only and does not guarantee the life of the Power Supply.

Many electronic components are used in the Power Supply and the Power Supply depends on the correct operation of these components to achieve the original Power Supply functions and performance. However, the influence of the ambient temperature on aluminum electrolytic capacitors is large, and the service life is reduced by half for each 10°C rise in temperature (Arrhenius law). When the capacity reduction life of the electrolytic capacitor is reached, the Power Supply failures or accidents may occur. We therefore recommend that you replace the Power Supply periodically to minimize product failures or accidents in advance.

* The recommended replacement period applies under the following conditions: rated input voltage, load rate of 50% max., ambient temperature of 40°C max., and the standard mounting method.

This product model is designed with a service life of 10 years minimum under the above conditions.

OMRON AUTOMATION AMERICAS HEADQUARTERS • Chicago, IL USA • 847.843.7900 • 800.556.6766 • automation.omron.com

OMRON CANADA, INC. • HEAD OFFICE

Toronto, ON, Canada • 416.286.6465 • 866.986.6766 • automation.omron.com

OMRON ELECTRONICS DE MEXICO • HEAD OFFICE

Ciudad de México • 52.55.5901.4300 • 01.800.386.6766 • mela@omron.com

OMRON ELECTRONICS DE MEXICO • SALES OFFICE

San Pedro Garza García, N.L. • 81.12.53.7392 • 01.800.386.6766 • mela@omron.com

OMRON ELECTRONICS DE MEXICO • SALES OFFICE

Eugenio Garza Sada, León, Gto • 01.800.386.6766 • mela@omron.com

OMRON ELETRÔNICA DO BRASIL LTDA • HEAD OFFICE

São Paulo, SP, Brasil • 55 11 5171-8920 • automation.omron.com

OMRON ARGENTINA • SALES OFFICE

Buenos Aires, Argentina • +54.11.4521.8630 • +54.11.4523.8483
mela@omron.com

OTHER OMRON LATIN AMERICA SALES

+54.11.4521.8630 • +54.11.4523.8483 • mela@omron.com

Authorized Distributor:

Controllers & I/O

- Machine Automation Controllers (MAC) • Motion Controllers
- Programmable Logic Controllers (PLC) • Temperature Controllers • Remote I/O

Robotics

- Industrial Robots • Mobile Robots

Operator Interfaces

- Human Machine Interface (HMI)

Motion & Drives

- Machine Automation Controllers (MAC) • Motion Controllers • Servo Systems
- Frequency Inverters

Vision, Measurement & Identification

- Vision Sensors & Systems • Measurement Sensors • Auto Identification Systems

Sensing

- Photoelectric Sensors • Fiber-Optic Sensors • Proximity Sensors
- Rotary Encoders • Ultrasonic Sensors

Safety

- Safety Light Curtains • Safety Laser Scanners • Programmable Safety Systems
- Safety Mats and Edges • Safety Door Switches • Emergency Stop Devices
- Safety Switches & Operator Controls • Safety Monitoring/Force-guided Relays

Control Components

- Power Supplies • Timers • Counters • Programmable Relays
- Digital Panel Meters • Monitoring Products

Switches & Relays

- Limit Switches • Pushbutton Switches • Electromechanical Relays
- Solid State Relays

Software

- Programming & Configuration • Runtime