

2 Watts

- Single Unregulated Output
- $\pm 10\%$ Input Range
- SMD DIP8 Package
- 1.5kVDC Isolation, 3kVDC Option
- Industry Standard Pinout
- Short Circuit Protection
- Tape & Reel Package Available
- Operating Temperature -40C to +105C
- Full load up to +85C
- 3 Year Warranty



Dimensions:

ISH:
0.500 x 0.44 x 0.285" (12.7 x 11.2 x 7.25 mm)

The ISH series provides a compact, cost effective isolated DC-DC power solution. With isolation of 1.5kV or 3kV this unregulated DC-DC series can be used in many industrial applications such as signal isolating circuits, digital and analogue circuits. Features include high MTBF and short circuit protection in a surface mount package.

Models & Ratings

Input Voltage	Output Voltage	Output Current	Input Current ⁽²⁾		Maximum Capacitive Load	Efficiency ⁽³⁾	Model Number ^(1,4)
			No Load	Full Load			
4.5-5.5	3.3V	400 mA	30 mA	506 mA	220 μ F	72%	ISH0503A ⁽¹⁾
	5V	400 mA	30 mA	506 mA	220 μ F	79%	ISH0505A ⁽¹⁾
	9V	222 mA	30 mA	506 mA	220 μ F	82%	ISH0509A ⁽¹⁾
	12V	167 mA	30 mA	506 mA	220 μ F	82%	ISH0512A ⁽¹⁾
	15V	133 mA	30 mA	506 mA	220 μ F	83%	ISH0515A ⁽¹⁾
10.8-13.2	5V	400 mA	25 mA	212 mA	220 μ F	79%	ISH1205A ⁽¹⁾
	9V	222 mA	25 mA	212 mA	220 μ F	82%	ISH1209A
	12V	167 mA	25 mA	212 mA	220 μ F	82%	ISH1212A ⁽¹⁾
	15V	133 mA	25 mA	212 mA	220 μ F	83%	ISH1215A ⁽¹⁾
13.5-16.5	24V	83 mA	25 mA	212 mA	220 μ F	84%	ISH1224A ⁽¹⁾
	15V	133 mA	18 mA	169 mA	220 μ F	83%	ISH1515A ⁽¹⁾
	5V	400 mA	15 mA	105 mA	220 μ F	79%	ISH2405A ⁽¹⁾
21.6-26.4	12V	167 mA	15 mA	105 mA	220 μ F	82%	ISH2412A ⁽¹⁾
	15V	133 mA	15 mA	105 mA	220 μ F	83%	ISH2415A ⁽¹⁾
	24V	83 mA	15 mA	105 mA	220 μ F	86%	ISH2424A ⁽¹⁾

Notes

1. For optional 3000 VDC isolation add suffix '-H' to end of part number e.g. ISH1224A-H.
2. Input currents measured at nominal input voltage.

3. Typical value at full load.
4. For optional tape & reel option add suffix -TR to the end of the p/n. Reel quantity = 500

Mechanical Details

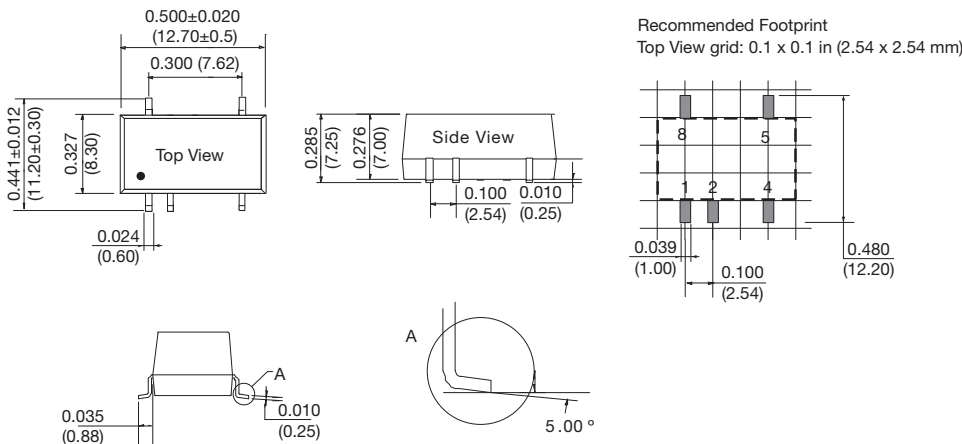

PIN CONNECTIONS	
Pin	Function
1	GND
2	+Vin
4	0 V
5	+Vout
8	No Connection

Notes

1. All dimensions are in inches (mm)
2. Weight: 0.003 lbs (1.5 g) typical.
3. Pin diameter: 0.02 \pm 0.002 (0.5 \pm 0.005)
4. Pin pitch and length tolerance: \pm 0.014 (\pm 0.35)
5. Case tolerance: \pm 0.02 (\pm 0.5)

Input

Characteristic	Minimum	Typical	Maximum	Units	Notes & Conditions
Input Voltage Range	4.50		5.50	VDC	5 V nominal
	10.80		13.20	VDC	12 V nominal
	13.50		16.50	VDC	15 V nominal
	21.60		26.40	VDC	24 V nominal
Input Current					See Models and Ratings table
Input Reflected Ripple		15		mA pk-pk	Through 12 μ H inductor and 47 μ F capacitor
Input Surge			9	VDC for 1 s	5 V models
			18	VDC for 1 s	12 V models
			21	VDC for 1 s	15 V models
			30	VDC for 1 s	24 V models
Input Filter	Capacitor				

Output

Characteristic	Minimum	Typical	Maximum	Units	Notes & Conditions
Output Voltage	3.3		24	VDC	See Models and Ratings table
Initial Set Accuracy				%	See Load Regulation Curves
Minimum Load	10			%	
Line Regulation			± 1.2	%	Per 1% change of input voltage ($\pm 1.5\%$ for 3V3 output)
Load Regulation				%	See graph
Start Up Delay		2		ms	
Ripple and Noise		100		mV pk-pk	20 MHz bandwidth, measured using 0.1 μ F capacitor
Transient Response			3	% deviation	Recovery to within 1% in 500 μ s for a 25% load change (5% max. deviation for 3.3 & 5 V models)
Short Circuit Protection			1	s	Cycle input supply to reset after short circuit removed
Maximum Capacitive Load			220	μ F	
Temperature Coefficient			0.03	%/°C	

General

Characteristic	Minimum	Typical	Maximum	Units	Notes & Conditions
Efficiency					See Models and Ratings table
Isolation: Input to Output	1500			VDC	For optional high isolation versions, 3000VDC input to output add suffix -H to model number
Switching Frequency	100	115	135	kHz	
Isolation Resistance	10^9			Ω	Input to output, tested at 500 VDC
Isolation Capacitance		20		pF	Input to output
Power Density			31.8	Win ³	
Mean Time Between Failure	3500			kHrs	MIL-HDBK-217F, +25 °C GB
Weight		0.003 (1.5)		lb (g)	
Recommended Solder Profile	Peak temp ≤ 245 °C, max duration, ≤ 60 s at 217 °C				
Case Material	Black plastic UL94V-0 rated				
Pin Material	C5191-1/2H Phosphor copper				
Water Wash	Not suitable for water washing				

Environmental

Characteristic	Minimum	Typical	Maximum	Units	Notes & Conditions
Operating Temperature	-40		+105	°C	See derating curve in application notes
Storage Temperature	-55		+125	°C	
Case Temperature			+115	°C	
Operating Humidity			95	% RH	Non-condensing
Cooling					Natural convection

Safety Approvals

Agency	Standard
CE	Meets all applicable directives
UKCA	Meets all applicable legislation

EMC: Emissions

Phenomenon	Standard	Test Level	Notes & Conditions
Conducted	EN55022	Class B	See Application Note for Class B filter
Radiated	EN55022	Class B	See Application Note for Class B filter

EMC: Immunity

Phenomenon	Standard	Test Level	Criteria	Notes & Conditions
ESD Immunity	EN61000-4-2	3	B	
Radiated Immunity	EN61000-4-3	3 V/m	A	
EFT/Burst	EN61000-4-4	2	B	External input capacitor required, 330 μ F/100 V
Surge	EN61000-4-5	2	B	External input capacitor required, 330 μ F/100 V
Conducted Immunity	EN61000-4-6	3 V rms	A	
Magnetic Fields	EN61000-4-8	1 A/m	A	

Load Regulation

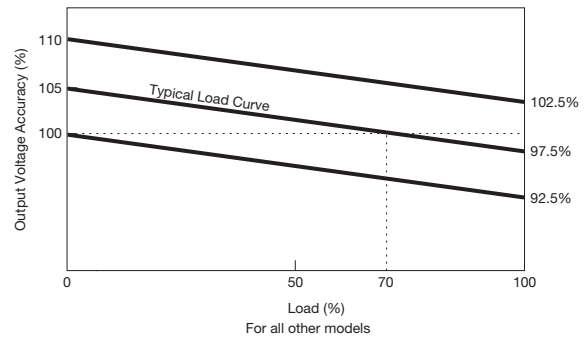
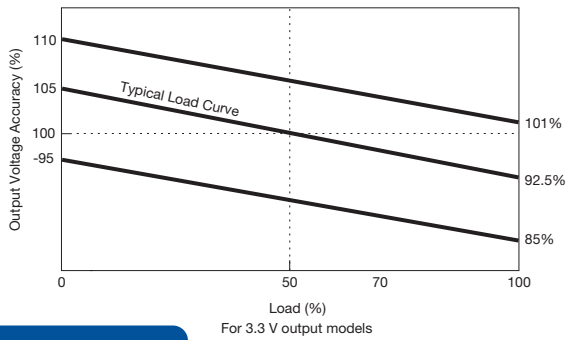

Application Note

EMI Filter for Class B Emissions

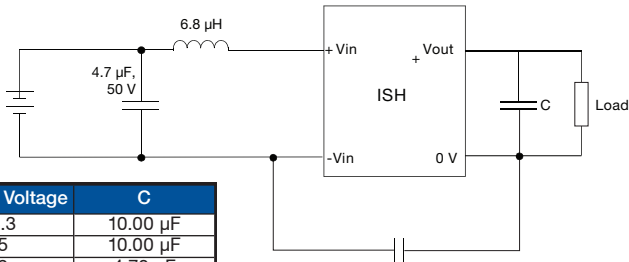

Output Voltage	C
3.3	10.00 μ F
5	10.00 μ F
9	4.70 μ F
12	2.20 μ F
15	1.00 μ F
24	0.47 μ F

For ISH2424A model only, add Ycap, 470 pF, 3 kv

Solder Profile

It is recommended to refer to IPC/JEDEC J-STD-020D standard for reflow soldering curve. The recommended reflow soldering temperature graph for our products is as follows:
(Note: The curve is only suitable for hot air convection reflow soldering.)

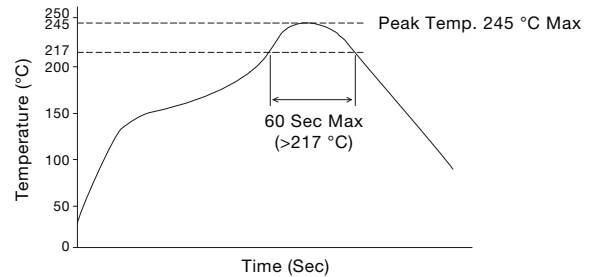

Derating curve

