

Wirewound Resistor, Industrial High Power, Vitreous Tubular, Adjustable, Low Values 0.12 Ω to 560 Ω

FEATURES

- High power rating: 16 W to 600 W at 25 °C
- Heavy overloads 10 P_n 5 s ≤ 1 %
- Low ohmic values 0.10 Ω available
- High long term stability drift < 1.5 % after 1000 h
- Excellent withstanding of thermal shock
- Mechanical strength
- Fire proof
- Material categorization: for definitions of compliance please see www.vishay.com/doc?99912

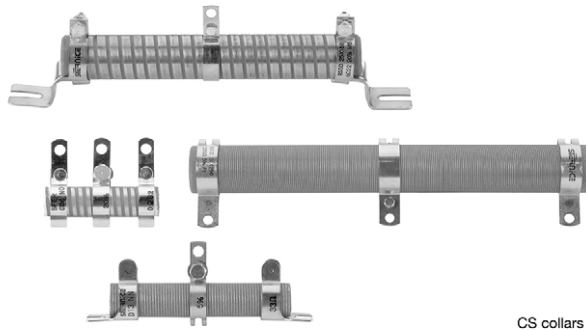

RoHS
COMPLIANT

LINKS TO ADDITIONAL RESOURCES

RSSD medium and high power resistors are noted for their ability to withstand heavy transient and severe shock and vibration conditions. They complement the ohmic range of Vishay styles RW, RWST and RA in the low value area, and can be tapped by means of adjustable collars. Standard RSSD resistors have a single adjustable collar.

NF F 16101, 10/1988 and 16102, 04/1992: Not applicable (our parts are made of metallic and refractory materials).

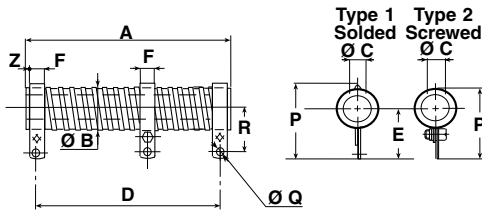
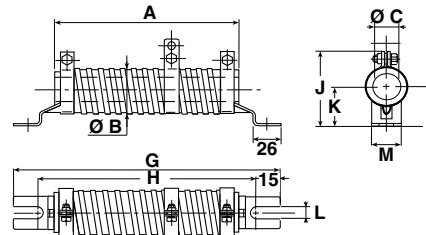
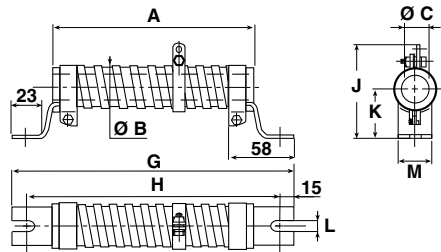
DIMENSIONS in millimeters

WELDED STAINLESS STEEL 304 L COLLARS "AN" TYPE 1

SCREWED STAINLESS STEEL 304 L COLLARS "CS" TYPE 1

SCREWED STAINLESS STEEL 304 L COLLARS "CS" TYPE 2

RSSD SERIES	CONNECTION	A ± 2	Ø B MAX.	Ø C MIN.	D	E	F + 0.5 + 0	P	Ø Q	R	Z APPROX.	AVERAGE UNIT WEIGHT IN g
8 x 34	AN type1	34	10	4.1	27 ± 2	20 ± 0.5	5	28 ± 1	3.2	16 ± 0.5	1	10
10 x 50	AN type1	50	11.5	5	40 ± 2	22 ± 0.5	6.35	31 ± 1	4.2	18 ± 0.5	1.5	22
13 x 70	AN type1 CS ⁽¹⁾	70	14.5	6.7	56 ± 2	24 ± 0.5	6.35	34 ± 1	4.2	20 ± 0.5	3.5	38
16 x 94	AN type1	94	18	9.2	78 ± 2	26.5 ± 0.5	6.35	38 ± 1	4.2	21 ± 0.5	4	55
20 x 117	AN type1	117	22	12.6	98 ± 2	31 ± 0.7	6.35	42 ± 1	4.2	24 ± 0.7	5	80

Note

⁽¹⁾ CS connections on request



DIMENSIONS in millimeters											
RSSD SERIES	CONNECTIONS		A ± 2	Ø B MAX.	Ø C MIN.	D	E	F + 0.5 + 0	G - 4 - 0	H - 4 - 0	J
25 x 138	AN type1	cs type1	138	27	16.4	117 ± 2	33.5 ± 1	9	199	169	50 ± 1.5
25 x 168	AN type1	cs type1	168	27	16.4	147 ± 2	33.5 ± 1	9	229	199	50 ± 1.5
30 x 250	AN type1	cs type1	250	32	21.3	227 ± 2.5	36 ± 1	13	317	287	60 ± 1.5
40 x 370	AN type2	cs type2	370	43	22.3	332 ± 3	57 ± 1.5	18	432	405	69 max.
50 x 373	AN type2	cs type2	373	53	27.1	332 ± 3	63 ± 1.5	18	432	405	80 max.
RSSD SERIES	CONNECTIONS		K	L ± 0.5	M ± 0.5	P	Ø Q	R	Z APPROX.	AVERAGE UNIT WEIGHT IN g	
										AN	CS
25 x 138	AN type1	cs type1	27 ± 1	6.5	24	51 ± 1.5	5.7	28.5 ± 1	6	90	135
25 x 168	AN type1	cs type1	27 ± 1	6.5	24	51 ± 1.5	5.7	28.5 ± 1	6	115	160
30 x 250	AN type1	cs type1	30 ± 1	9	25	55 ± 1.5	5.7	31 ± 1	5	240	290
40 x 370	AN type2	cs type2	45 ± 1	9	30	81.5 max.	9.2	45 ± 1.5	10	845	925
50 x 373	AN type2	cs type2	51 ± 1.5	9	30	92.5 max.	9.2	51 ± 1.5	11.5	1270	1350

STANDARD ELECTRICAL SPECIFICATIONS				
MODEL	SIZE	RESISTANCE RANGE Ω	RATED POWER $P_{25^{\circ}\text{C}}$ W	TOLERANCE ± %
RSSD 8 x 34	0834	0.12 to 10	16	5, 10, 20
RSSD 10 x 50	1050	0.12 to 22	25	5, 10, 20
RSSD 13 x 70	1370	0.12 to 43	42	5, 10, 20
RSSD 16 x 94	1694	0.33 to 75	70	5, 10, 20
RSSD 20 x 117	20117	0.22 to 100	100	5, 10, 20
RSSD 25 x 138	25138	0.10 to 150	140	5, 10, 20
RSSD 25 x 168	25168	0.12 to 220	200	5, 10, 20
RSSD 30 x 250	30250	0.22 to 360	280	5, 10, 20
RSSD 40 x 370	40370	0.47 to 470	450	5, 10, 20
RSSD 50 x 373	50373	0.68 to 560	600	5, 10, 20

MECHANICAL SPECIFICATIONS	
Mechanical Protection	Vishay Sfernice special cement
Resistive Element	Nickel alloy wire
Connections	AN collars CS supporting collars
Average Unit Weight	10 g to 1350 g

TECHNICAL SPECIFICATIONS	
Resistance Range	0.12 Ω to 560 Ω (E12 series)
Standard Tolerance	$R \geq 10 \Omega \pm 5\%$ ⁽¹⁾ $1 \Omega \leq R < 10 \Omega \pm 10\%$ $0.1 \Omega \leq R < 1 \Omega \pm 20\%$
Power Rating	14 W to 600 W at 25 °C

Note⁽¹⁾ 10 % for RSSD 8 x 34 only

ENVIRONMENTAL SPECIFICATIONS	
Temperature Range	-55 °C, +450 °C
Climatic Category	-55 °C / +200 °C / 56 days

PERFORMANCE			
TESTS	CONDITIONS	REQUIREMENTS	TYPICAL VALUES AND DRIFTS
Short Time Overload	10 P_r during 5 s	2 %	1 %
Climatic Sequence	-55 °C, +200 °C 5 cycles	3 %	1 %
Thermal Shock	Load at 100 % P_r followed by cold -55 °C / 15	2 % or 0.05 Ω	1 %
Load Life	90 / 30 cycle 1000 h at P_r at +25 °C	5 %	5 %



SPECIAL FEATURES											
RSSD TYPE		8 x 34	10 x 50	13 x 70	16 x 94	20 x 117	25 x 138	25 x 168	30 x 250	40 x 370	50 x 373
Power Rating at 25 °C	Continuous	16 W	25 W	42 W	70 W	100 W	140 W	200 W	280 W	450 W	600 W
	Reduced	14 W	22 W	38 W	62 W	90 W	125 W	170 W	240 W	360 W	450 W
Resistance Ohmic Range (E12, E24 Series) with 1 Tapping		0.12 Ω 10 Ω	0.12 Ω 22 Ω	0.12 Ω 43 Ω	0.33 Ω 75 Ω	0.22 Ω 100 Ω	0.10 Ω 150 Ω	0.12 Ω 220 Ω	0.22 Ω 360 Ω	0.47 Ω 470 Ω	0.68 Ω 560 Ω
Maximum Number of Additional Tapping		0	1	1	1	1	1	2	2	4	4
Reduction % of Ohmic Value by Tapping		23	21	14	11	10	8	6.5	6	5.7	5.7

ADDITIONAL TAPPINGS

Are supplied with their adjustable collars fastened but not set to any specific value. Please note that, on request, all tappings can be adjusted by Vishay Sfernice. For adjustment purposes we would need to be advised of the ohmic values, and tolerances of the sections in successive order in addition to their sum R_n .

The permissible maximum value for an adjustment should take into account the possible negative tolerance of R_n .

Please consult Vishay Sfernice regarding the acceptable tolerance.

RECOMMENDATIONS FOR USE

Maximum Current Strength:

The ohmic value and the power decrease as the connections are brought together. To avoid overload, the maximum current strength that is permissible for R_n should never be exceeded:

$$I_{max.} = \sqrt{P_r/R_n}$$

POWER RATING

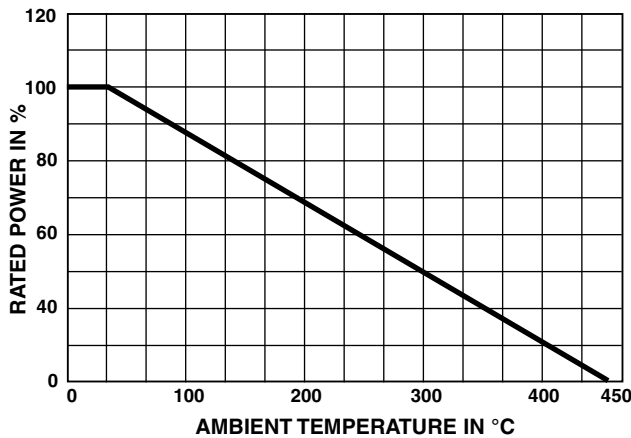

TEMPERATURE RISE

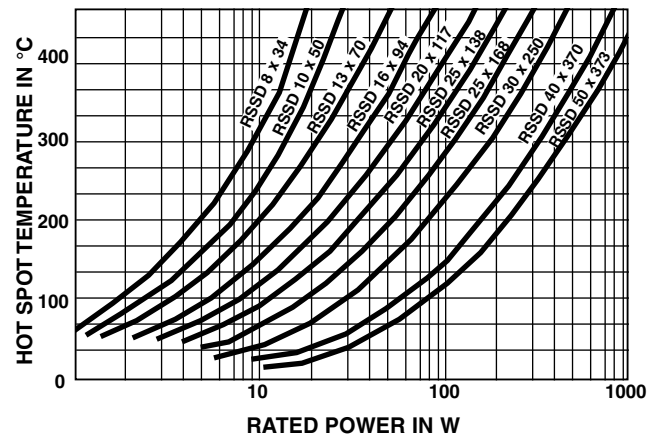

MARKING

Vishay Sfernice trademark, model, style, nominal resistance (in Ω), tolerance (in %), manufacturing date.

ORDERING INFORMATION							
RSSD	10 x 50		AN	10U	5 %	BA25	e
MODEL	STYLE	SPECIAL DESIGN	CONNECTIONS	OHMIC VALUE	TOLERANCE	PACKAGING	LEAD (Pb)-FREE
		Method N° Optional		Custom items are subject to extra-charge and min. order. Please see price list.			



GLOBAL PART NUMBER INFORMATION																				
R	S	S	D	2	5	1	3	8	A	1	5	R	0	J	B	1	5			
GLOBAL MODEL	SIZE	LEADS	OHMIC VALUE									TOLERANCE	PACKAGING	SPECIAL						
RSSD	08 x 34 10 x 50 13 x 70 16 x 94 20 x 117 25 x 138 25 x 168 30 x 250 40 x 370 50 x 373	A = AN B = B C = CS F = faston	The three first digits are significant figures and the last digit specifies the number of zeros to follow. R designates decimal point. 4700 = 470 Ω 48R5 = 48.5 Ω R010 = 0.01 Ω ...									J = 5 % K = 10 % M = 20 %	Standard packaging: BXX = box, XXPCS (fixed qty depending on size) No standard packaging: B00 = box, qty open	As applicable. Example: CB4						

RELATED DOCUMENTS

APPLICATION NOTES	
Packaging Information	www.vishay.com/doc?50033
Accessories	www.vishay.com/doc?50021



Disclaimer

ALL PRODUCT, PRODUCT SPECIFICATIONS AND DATA ARE SUBJECT TO CHANGE WITHOUT NOTICE TO IMPROVE RELIABILITY, FUNCTION OR DESIGN OR OTHERWISE.

Vishay Intertechnology, Inc., its affiliates, agents, and employees, and all persons acting on its or their behalf (collectively, "Vishay"), disclaim any and all liability for any errors, inaccuracies or incompleteness contained in any datasheet or in any other disclosure relating to any product.

Vishay makes no warranty, representation or guarantee regarding the suitability of the products for any particular purpose or the continuing production of any product. To the maximum extent permitted by applicable law, Vishay disclaims (i) any and all liability arising out of the application or use of any product, (ii) any and all liability, including without limitation special, consequential or incidental damages, and (iii) any and all implied warranties, including warranties of fitness for particular purpose, non-infringement and merchantability.

Statements regarding the suitability of products for certain types of applications are based on Vishay's knowledge of typical requirements that are often placed on Vishay products in generic applications. Such statements are not binding statements about the suitability of products for a particular application. It is the customer's responsibility to validate that a particular product with the properties described in the product specification is suitable for use in a particular application. Parameters provided in datasheets and / or specifications may vary in different applications and performance may vary over time. All operating parameters, including typical parameters, must be validated for each customer application by the customer's technical experts. Product specifications do not expand or otherwise modify Vishay's terms and conditions of purchase, including but not limited to the warranty expressed therein.

Hyperlinks included in this datasheet may direct users to third-party websites. These links are provided as a convenience and for informational purposes only. Inclusion of these hyperlinks does not constitute an endorsement or an approval by Vishay of any of the products, services or opinions of the corporation, organization or individual associated with the third-party website. Vishay disclaims any and all liability and bears no responsibility for the accuracy, legality or content of the third-party website or for that of subsequent links.

Vishay products are not designed for use in life-saving or life-sustaining applications or any application in which the failure of the Vishay product could result in personal injury or death unless specifically qualified in writing by Vishay. Customers using or selling Vishay products not expressly indicated for use in such applications do so at their own risk. Please contact authorized Vishay personnel to obtain written terms and conditions regarding products designed for such applications.

No license, express or implied, by estoppel or otherwise, to any intellectual property rights is granted by this document or by any conduct of Vishay. Product names and markings noted herein may be trademarks of their respective owners.