

APPLICABLE STANDARD								
RATING	OPERATING TEMPERATURE RANGE	-40°C TO +85°C		STORAGE TEMPERATURE RANGE	-30°C TO +70°C			
	POWER	2 W		CHARACTERISTIC IMPEDANCE	50 Ω			
	FREQUENCY RANGE	0.045 TO 8 GHz		OPERATING HUMIDITY RANGE	TO 90%			
	PECULIARITY	—		APPLICABLE CABLE	—			
SPECIFICATIONS								
ITEM	TEST METHOD			REQUIREMENTS			QT	AT
CONSTRUCTION								
GENERAL EXAMINATION	VISUALLY AND BY MEASURING INSTRUMENT.			ACCORDING TO DRAWING.			x	x
ELECTRIC CHARACTERISTICS								
CONTACT RESISTANCE ※1	100 mA MAX (DC OR 1000 Hz).			CENTER CONTACT	100 mΩ MAX.		x	x
				OUTER CONTACT	100 mΩ MAX.			
INSULATION RESISTANCE	100 V DC.			1000 MΩ MIN.			x	—
VOLTAGE PROOF	100 V AC FOR 1 min.			NO FLASHOVER OR BREAKDOWN.			x	x
V.S.W.R. ※1	FREQUENCY	DC TO	3.0 GHz	1.3 MAX		x	—	
	FREQUENCY	3.0 TO	8.0 GHz	1.4 MAX				
INSERTION LOSS ※1	FREQUENCY	DC TO	3.0 GHz	0.4 dB MAX.		x	—	
	FREQUENCY	3.0 TO	6.0 GHz	0.6 dB MAX.				
	FREQUENCY	6.0 TO	8.0 GHz	0.8 dB MAX.				
ISOLATION	FREQUENCY	TO	GHz	dB MIN.		—	—	
MECHANICAL CHARACTERISTICS								
MECHANICAL OPERATION	10000 TIMES INSERTIONS AND EXTRACTIONS.			1) ACORDING TO THE V.S.W.R. AND THE INSERTION LOSS SPEC. ABOVE. 2) NO DAMAGE, CRACK AND LOOSENESS OF PARTS.			x	—
VIBRATION	FREQUENCY 10 TO 55 Hz SINGLE AMPLITUDE 0.75 mm OR 98 m/s ² 1 octave/min , 10 CYCLES FOR EACH 3 DIRECTIONS.			1) CONTACT RESISTANCE ※1 CENTER :100mΩ MAX. OUTER :100mΩ MAX.			x	—
SHOCK	ACCELERATION : 490 m/s ² DURATION : 11 ms , HALF SINE WAVE 3 BOTH AXIAL DIRECTIONS, 3 TIMES EACH			2) ACCORDING TO THE VOLTAGE PROOF SPEC. ABOVE. 3) NO DAMAGE, CRACK AND LOOSENESS OF PARTS.			x	—
<div style="border: 1px solid black; padding: 5px; display: inline-block;">RoHS COMPLIANT</div>								
	COUNT	DESCRIPTION OF REVISIONS		DESIGNED		CHECKED		DATE
Q								
REMARK				APPROVED	MH. YAMANE		11. 12. 08	
※1. This specification includes MS-180				CHECKED	NK. NINOMIYA		11. 12. 08	
Unless otherwise specified, refer to IEC-60512.				DESIGNED	TS. NAKAGAWA		11. 12. 06	
				DRAWN	TS. NAKAGAWA		11. 12. 06	
Note QT:Qualification Test AT:Assurance Test x:Applicable Test				DRAWING NO.		ELC4-342466-00		
SPECIFICATION SHEET				PART NO.	MS-180-HRMJ-3			
HIROSE ELECTRIC CO., LTD.				CODE NO.	CL358-0318-1-00			1/1

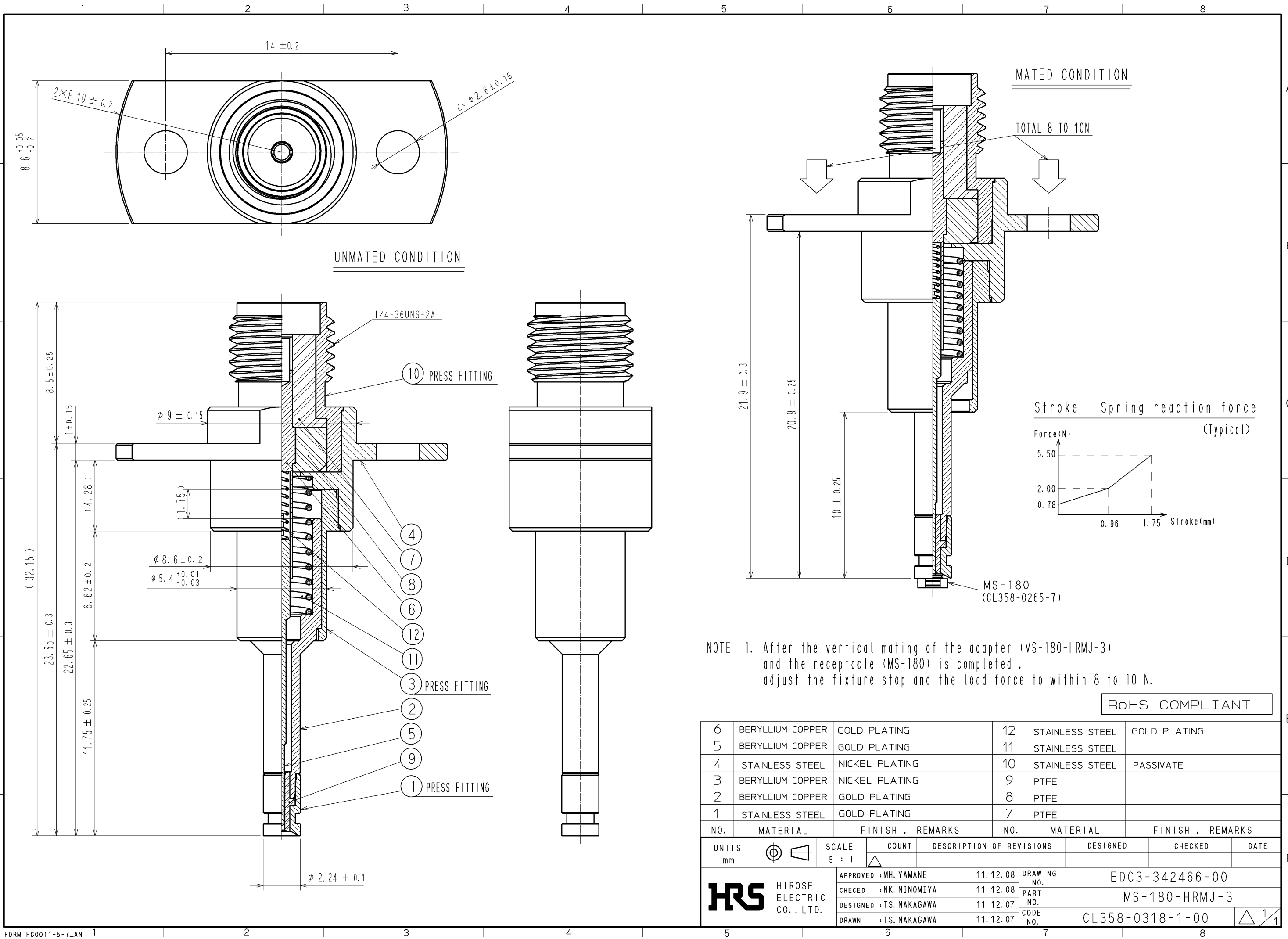

NOTE 1. After the vertical mating of the adapter (MS-180-HRMJ-3) and the receptacle (MS-180) is completed, adjust the fixture stop and the load force to within 8 to 10 N.

RoHS COMPLIANT

NO.	MATERIAL	FINISH	REMARKS	NO.	MATERIAL	FINISH	REMARKS
6	BERYLLIUM COPPER	GOLD PLATING		12	STAINLESS STEEL	GOLD PLATING	
5	BERYLLIUM COPPER	GOLD PLATING		11	STAINLESS STEEL		
4	STAINLESS STEEL	NICKEL PLATING		10	STAINLESS STEEL	PASSIVATE	
3	BERYLLIUM COPPER	NICKEL PLATING		9	PTFE		
2	BERYLLIUM COPPER	GOLD PLATING		8	PTFE		
1	STAINLESS STEEL	GOLD PLATING		7	PTFE		

UNITS	SCALE	COUNT	DESCRIPTION OF REVISIONS	DESIGNED	CHECKED	DATE
mm	5 : 1	△				
HRS HIROSE ELECTRIC CO., LTD.			APPROVED : MH. YAMANE 11.12.08 CHECKED : NK. NINOMIYA 11.12.08 DESIGNED : TS. NAKAGAWA 11.12.07 DRAWN : TS. NAKAGAWA 11.12.07	DRAWING NO. EDC3-342466-00 PART NO. MS-180-HRMJ-3 CODE NO. CL358-0318-1-00		