



e.MMC™ Memory

**MTFC16GAKAECN-4M IT, MTFC16GAKAEJP-4M IT,
MTFC16GAKAENA-4M IT, MTFC32GAKAECN-4M IT,
MTFC32GAKAEJP-4M IT, MTFC32GAKAENA-4M IT,
MTFC64GAKAEEY-4M IT, MTFC64GAKAEYF-4M IT**

Features

- MultiMediaCard (MMC) controller and NAND Flash
- 153-ball VFBGA (RoHS compliant, "green package")
- 153-ball LFBGA (RoHS compliant, "green package")
- 100-ball TBGA (RoHS compliant, "green package")
- V_{CC} : 2.7–3.6V
- V_{CCQ} (dual voltage): 1.65–1.95V; 2.7–3.6V
- Temperature ranges (ambient)
 - Operating temperature: -40°C to $+85^{\circ}\text{C}$
 - Storage temperature: -40°C to $+85^{\circ}\text{C}$

MMC-Specific Features

- JEDEC/MMC standard version 5.0-compliant (JEDEC Standard No. JESD84-B50)¹
 - Advanced 12-signal interface
 - x1, x4, and x8 I/Os, selectable by host
 - SDR/DDR modes up to 52 MHz clock speed
 - HS200/HS400 modes
 - Real-time clock
 - Command classes: class 0 (basic); class 2 (block read); class 4 (block write); class 5 (erase); class 6 (write protection); class 7 (lock card)
 - Temporary write protection
 - Boot operation (high-speed boot)
 - Sleep mode
 - Replay-protected memory block (RPMB)
 - Secure erase and secure trim
 - Hardware reset signal
 - Multiple partitions with enhanced attribute
 - Permanent and power-on write protection
 - High-priority interrupt (HPI)
 - Background operation
 - Reliable write
 - Discard and sanitize
 - Extended partitioning
 - Context ID

Figure 1: Micron e-MMC Device

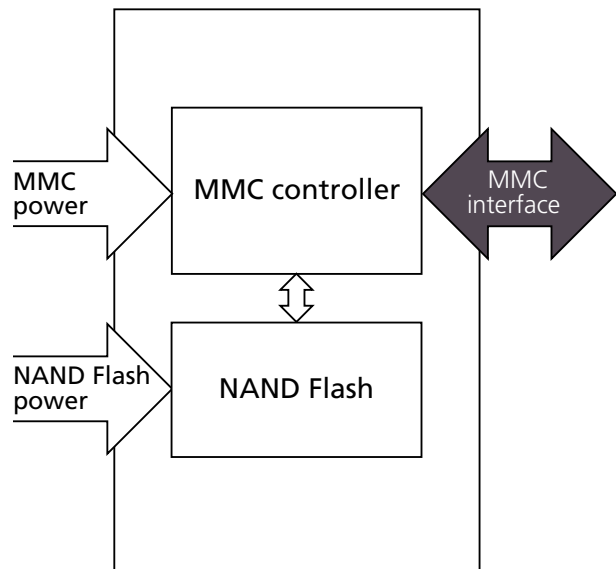

MMC-Specific Features (Continued)

- Data TAG
- Packed commands
- Dynamic device capacity
- Backward compatible with previous MMC
- Cache
- Field firmware update (FFU)
- Device health report
- Sleep notification
- Power-off notification
- ECC and block management implemented

Note: 1. The JEDEC specification is available at www.jedec.org/sites/default/files/docs/JESD84-B50.pdf.



e.MMC Performance and Current Consumption by Bus Mode

Table 1: MLC Partition Performance

Condition ¹	Typical Values			Unit
	16GB	32GB	64GB	
HS400				
Sequential write	30	40	50	MB/s
Sequential read	250	250	280	MB/s
Random write (cache on)	5200	5650	5800	IOPS
Random write (cache off)	1130	1200	1300	IOPS
Random read	4000	4500	4700	IOPS
HS200				
Sequential write	30	40	40	MB/s
Sequential read	160	160	160	MB/s
Random write (cache on)	5200	5650	5800	IOPS
Random write (cache off)	1130	1200	1300	IOPS
Random read	4000	4500	4700	IOPS
DDR52				
Sequential write	30	40	40	MB/s
Sequential read	90	90	90	MB/s
Random write (cache on)	5200	5650	5800	IOPS
Random write (cache off)	1130	1200	1300	IOPS
Random read	3800	4000	4200	IOPS

Note: 1. Bus in x8 I/O mode. Sequential access of 1MB chunk; random access of 4KB chunk over 1GB span. Additional performance data, such as system performance on a specific application board, will be provided in a separate document upon customer request.

Table 2: Current Consumption

Condition ¹	Typical Values (I _{CC} /I _{CCQ})			Unit
	16GB	32GB	64GB	
HS400				
Write	110/25	115/25	160/30	mA
Read	125/50	140/50	155/60	mA
HS200				
Write	110/25	115/25	160/30	mA
Read	125/50	135/50	120/60	mA
DDR52				
Write	110/30	115/30	75/30	mA
Read	80/35	80/35	125/35	mA
Idle/Standby				

Table 2: Current Consumption (Continued)

Condition ¹	Typical Values (I_{CC}/I_{CCQ})			Unit
	16GB	32GB	64GB	
Sleep	0/140	0/145	0/100	μA
Auto standby	50/140	50/145	60/100	μA

Note: 1. Bus in x8 I/O mode. $V_{CC} = 3.6\text{V}$ and $V_{CCQ} = 1.95\text{V}$. 25°C . Measurements done as average RMS current consumption. I_{CCQ} in READ operation measurements with tester load disconnected.



Part Numbering Information

Micron® e-MMC memory devices are available in different configurations and densities.

Figure 2: e-MMC Part Numbering

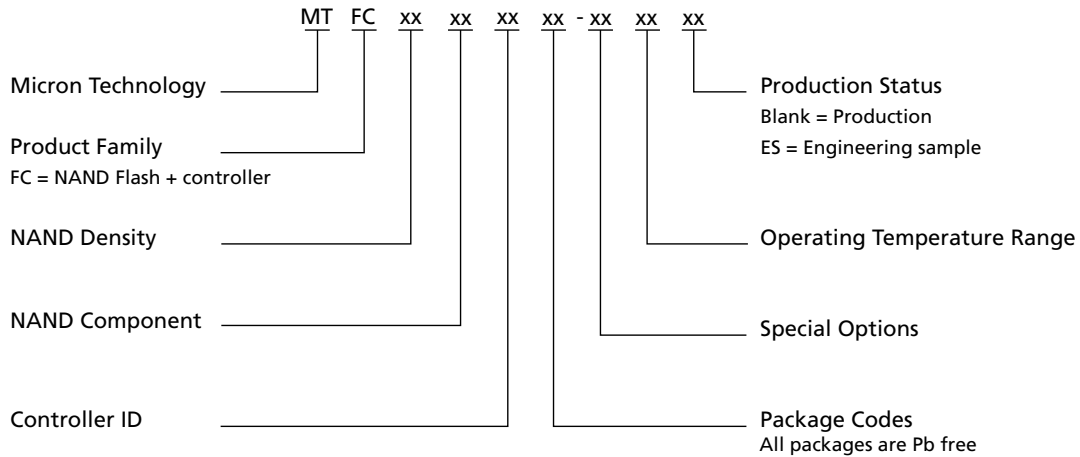

Table 3: Ordering Information

Base Part Number	Density	Package	Shipping
MTFC16GAKAECN-4M IT MTFC16GAKAEJP-4M IT	16GB	153-ball VFBGA 11.5mm x 13mm x 1.0mm	Tray Tape and reel
MTFC16GAKAENA-4M IT	16GB	100-ball TBGA 14mm x 18mm x 1.2mm	Tray Tape and reel
MTFC32GAKAECN-4M IT MTFC32GAKAEJP-4M IT	32GB	153-ball VFBGA 11.5mm x 13mm x 1.0mm	Tray Tape and reel
MTFC32GAKAENA-4M IT	32GB	100-ball TBGA 14mm x 18mm x 1.2mm	Tray Tape and reel
MTFC64GAKAEEY-4M IT MTFC64GAKAEYF-4M IT	64GB	153-ball LFBGA 11.5mm x 13mm x 1.4mm	Tray Tape and reel

Device Marking

Due to the size of the package, the Micron-standard part number is not printed on the top of the device. Instead, an abbreviated device mark consisting of a 5-digit alphanumeric code is used. The abbreviated device marks are cross-referenced to the Micron part numbers at the FBGA Part Marking Decoder site: www.micron.com/decoder.



Important Notes and Warnings

Micron Technology, Inc. ("Micron") reserves the right to make changes to information published in this document, including without limitation specifications and product descriptions. This document supersedes and replaces all information supplied prior to the publication hereof. You may not rely on any information set forth in this document if you obtain the product described herein from any unauthorized distributor or other source not authorized by Micron.

Automotive Applications. Products are not designed or intended for use in automotive applications unless specifically designated by Micron as automotive-grade by their respective data sheets. Distributor and customer/distributor shall assume the sole risk and liability for and shall indemnify and hold Micron harmless against all claims, costs, damages, and expenses and reasonable attorneys' fees arising out of, directly or indirectly, any claim of product liability, personal injury, death, or property damage resulting directly or indirectly from any use of non-automotive-grade products in automotive applications. Customer/distributor shall ensure that the terms and conditions of sale between customer/distributor and any customer of distributor/customer (1) state that Micron products are not designed or intended for use in automotive applications unless specifically designated by Micron as automotive-grade by their respective data sheets and (2) require such customer of distributor/customer to indemnify and hold Micron harmless against all claims, costs, damages, and expenses and reasonable attorneys' fees arising out of, directly or indirectly, any claim of product liability, personal injury, death, or property damage resulting from any use of non-automotive-grade products in automotive applications.

Critical Applications. Products are not authorized for use in applications in which failure of the Micron component could result, directly or indirectly in death, personal injury, or severe property or environmental damage ("Critical Applications"). Customer must protect against death, personal injury, and severe property and environmental damage by incorporating safety design measures into customer's applications to ensure that failure of the Micron component will not result in such harms. Should customer or distributor purchase, use, or sell any Micron component for any critical application, customer and distributor shall indemnify and hold harmless Micron and its subsidiaries, subcontractors, and affiliates and the directors, officers, and employees of each against all claims, costs, damages, and expenses and reasonable attorneys' fees arising out of, directly or indirectly, any claim of product liability, personal injury, or death arising in any way out of such critical application, whether or not Micron or its subsidiaries, subcontractors, or affiliates were negligent in the design, manufacture, or warning of the Micron product.

Customer Responsibility. Customers are responsible for the design, manufacture, and operation of their systems, applications, and products using Micron products. ALL SEMICONDUCTOR PRODUCTS HAVE INHERENT FAILURE RATES AND LIMITED USEFUL LIVES. IT IS THE CUSTOMER'S SOLE RESPONSIBILITY TO DETERMINE WHETHER THE MICRON PRODUCT IS SUITABLE AND FIT FOR THE CUSTOMER'S SYSTEM, APPLICATION, OR PRODUCT. Customers must ensure that adequate design, manufacturing, and operating safeguards are included in customer's applications and products to eliminate the risk that personal injury, death, or severe property or environmental damages will result from failure of any semiconductor component.

Limited Warranty. In no event shall Micron be liable for any indirect, incidental, punitive, special or consequential damages (including without limitation lost profits, lost savings, business interruption, costs related to the removal or replacement of any products or rework charges) whether or not such damages are based on tort, warranty, breach of contract or other legal theory, unless explicitly stated in a written agreement executed by Micron's duly authorized representative.



General Description

Micron *e.MMC* is a communication and mass data storage device that includes a Multi-MediaCard (MMC) interface, a NAND Flash component, and a controller on an advanced 12-signal bus, which is compliant with the MMC system specification. Its cost per bit, small package sizes, and high reliability make it an ideal choice for industrial applications like infrastructure and networking equipment, PC and servers, a variety of other industrial products.

The nonvolatile *e.MMC* draws no power to maintain stored data, delivers high performance across a wide range of operating temperatures, and resists shock and vibration disruption.



Signal Descriptions

Table 4: Signal Descriptions

Symbol	Type	Description
CLK	Input	Clock: Each cycle of the clock directs a transfer on the command line and on the data line(s). The frequency can vary between the minimum and the maximum clock frequency.
RST_n	Input	Reset: The RST_n signal is used by the host for resetting the device, moving the device to the pre-idle state. By default, the RST_n signal is temporarily disabled in the device. The host must set ECSD register byte 162, bits[1:0] to 0x1 to enable this functionality before the host can use it.
CMD	I/O	Command: This signal is a bidirectional command channel used for command and response transfers. The CMD signal has two bus modes: open-drain mode and push-pull mode. Commands are sent from the MMC host to the device, and responses are sent from the device to the host.
DAT[7:0]	I/O	Data I/O: These are bidirectional data signals. The DAT signals operate in push-pull mode. By default, after power-on or assertion of the RST_n signal, only DAT0 is used for data transfer. The MMC controller can configure a wider data bus for data transfer either using DAT[3:0] (4-bit mode) or DAT[7:0] (8-bit mode). The device includes internal pull-up resistors for data lines DAT[7:1]. Immediately after entering the 4-bit mode, the device disconnects the internal pull-up resistors on the DAT[3:1] lines. Upon entering the 8-bit mode, the device disconnects the internal pull-ups on the DAT[7:1] lines.
DS	Output	Data strobe: Generated by the device and used for data output and CRC status response output in HS400 mode. The frequency of this signal follows the frequency of CLK. For data output, each cycle of this signal directs two bits transfer (2x) on the data, one bit for the positive edge and the other bit for the negative edge. For CRC status response output, the CRC status is latched on the positive edge only, and is "Don't Care" on the negative edge.
V _{CC}	Supply	V _{CC} : NAND interface (I/F) I/O and NAND Flash power supply.
V _{CCQ}	Supply	V _{CCQ} : e.MMC controller core and e.MMC I/F I/O power supply.
V _{SS} ¹	Supply	V _{SS} : NAND I/F I/O and NAND Flash ground connection.
V _{SSQ} ¹	Supply	V _{SSQ} : e.MMC controller core and e.MMC I/F ground connection.
V _{DDIM}		Internal voltage node. Do not tie to supply voltage or ground.
NC	–	No connect: No internal connection is present.
RFU	–	Reserved for future use: No internal connection is present. Leave it floating externally.

Note: 1. V_{SS} and V_{SSQ} are connected internally.



153-Ball Signal Assignments

Figure 3: 153 Ball (Top View, Ball Down)

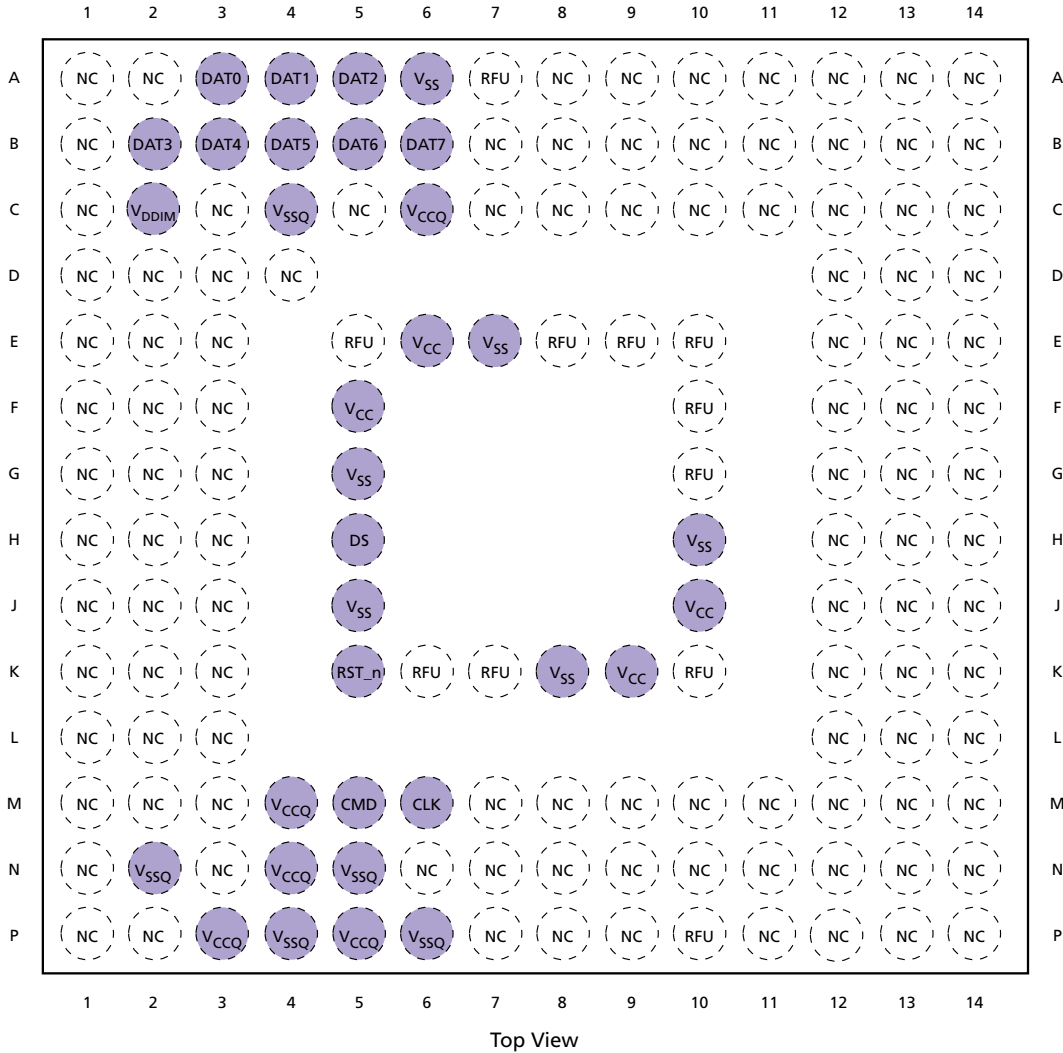

- Notes:
1. Some previous versions of the JEDEC product or mechanical specification had defined reserved for future use (RFU) balls as no connect (NC) balls. NC balls assigned in the previous specifications could have been connected to ground on the system board. To enable new feature introduction, some of these balls are assigned as RFU in the v4.4 mechanical specification. Any new PCB footprint implementations should use the new ball assignments and leave the RFU balls floating on the system board.
 2. VCC, VCCQ, VSS, and VSSQ balls must all be connected on the system board.



100-Ball Signal Assignments

Figure 4: 100 Ball (Top View, Ball Down)

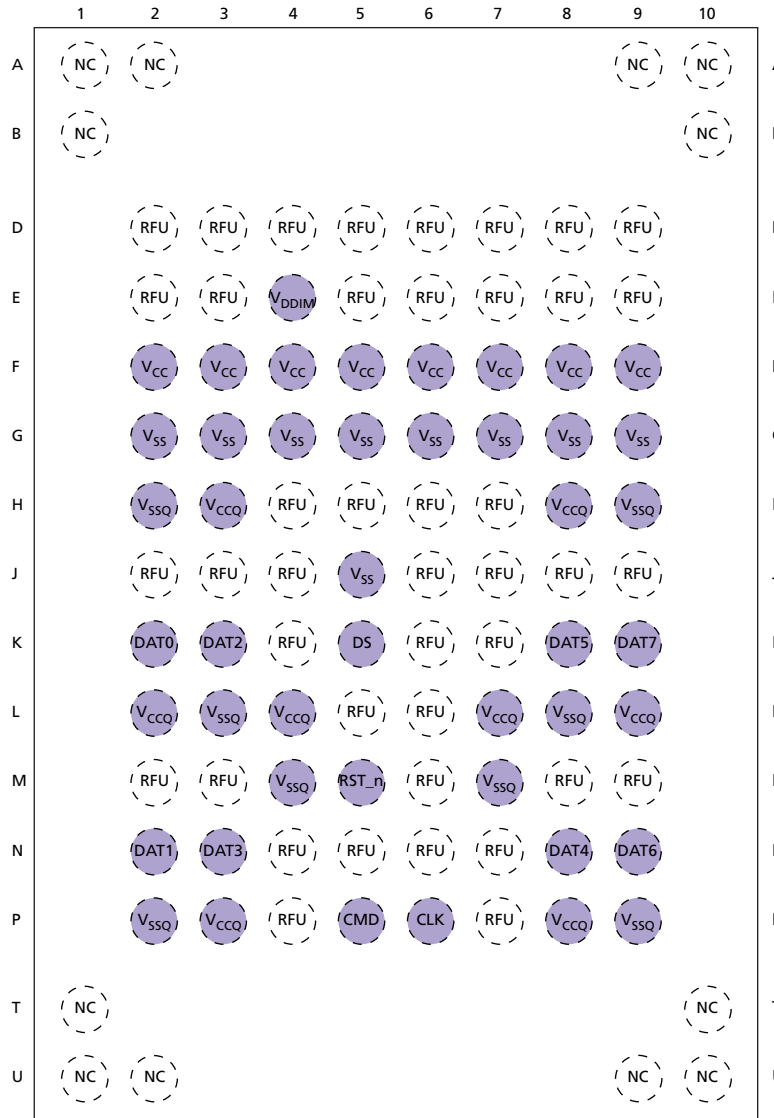

- Notes:
1. Connect a 1 μ F decoupling capacitor from V_{DDIM} to ground.
 2. Some previous versions of the JEDEC product or mechanical specification had defined reserved for future use (RFU) balls as no connect (NC) balls. NC balls assigned in the previous specifications could have been connected to ground on the system board. To enable new feature introduction, some of these balls are assigned as RFU in the v4.4 mechanical specification. Any new PCB footprint implementations should use the new ball assignments and leave the RFU balls floating on the system board.
 3. V_{CC}, V_{CCQ}, V_{SS}, and V_{SSQ} balls must all be connected on the system board.



Package Dimensions

Figure 5: 153-Ball VFBGA – 11.5mm x 13.0mm x 1.0mm (Package Codes: JP, CN)

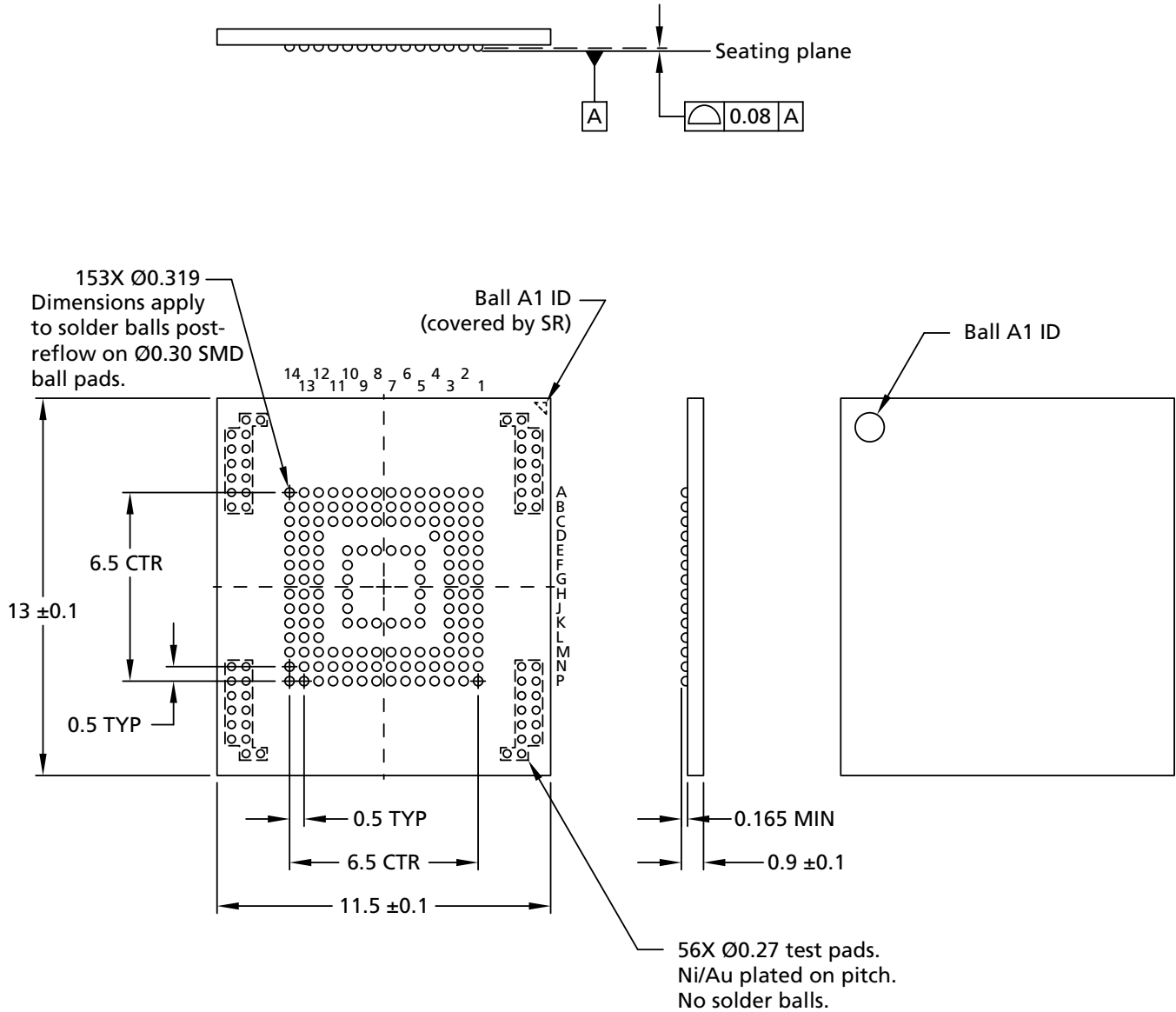

- Notes: 1. Dimensions are in millimeters
2. SAC302 Solder Ball



Figure 6: 153-Ball LFBGA – 11.5mm x 13.0mm x 1.4mm (Package Codes: YF, EY)

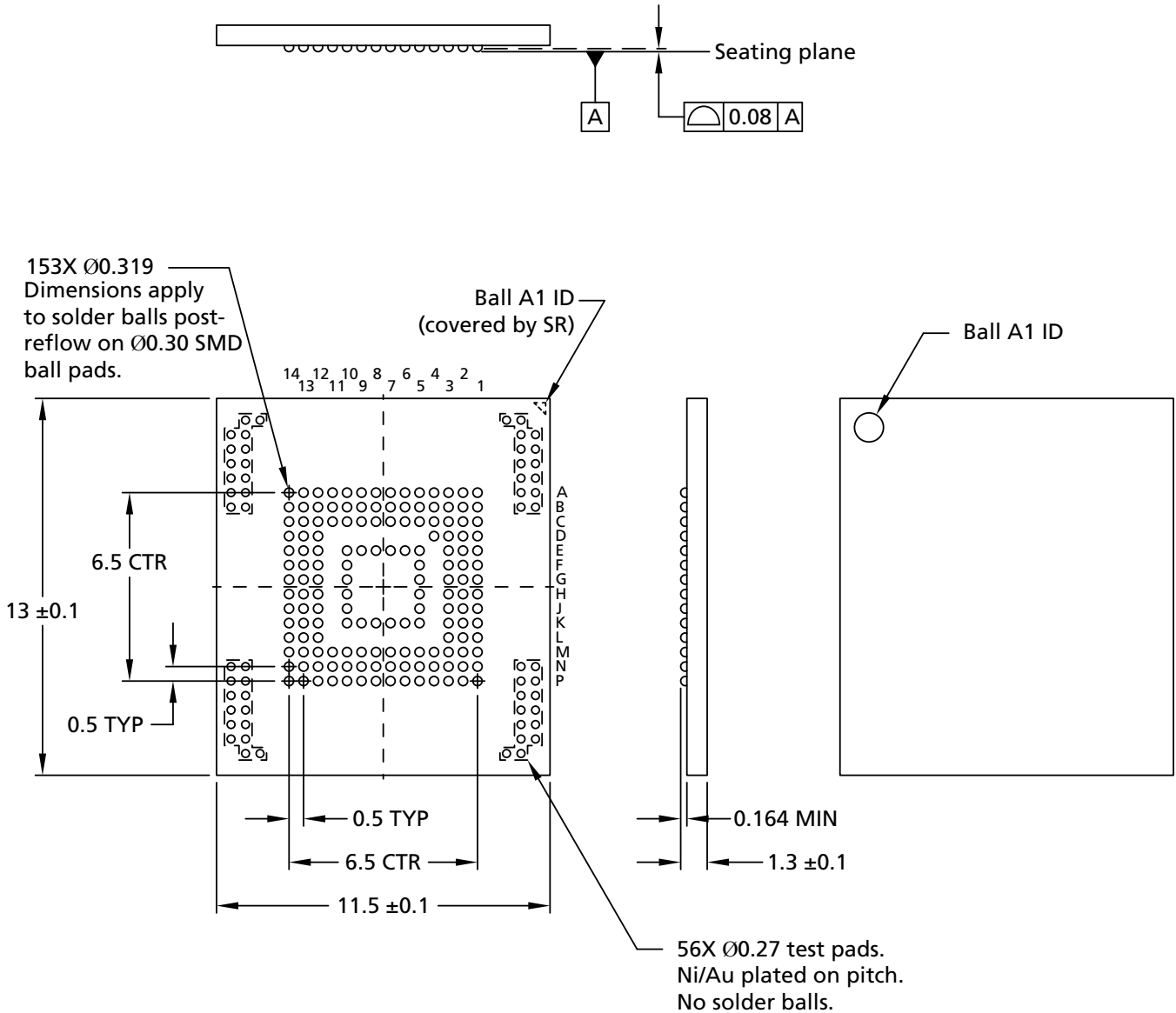

- Notes: 1. Dimensions are in millimeters
2. SAC302 Solder Ball



Figure 7: 100-Ball TBGA – 14mm x 18mm x 1.2mm (Package Code: NA)

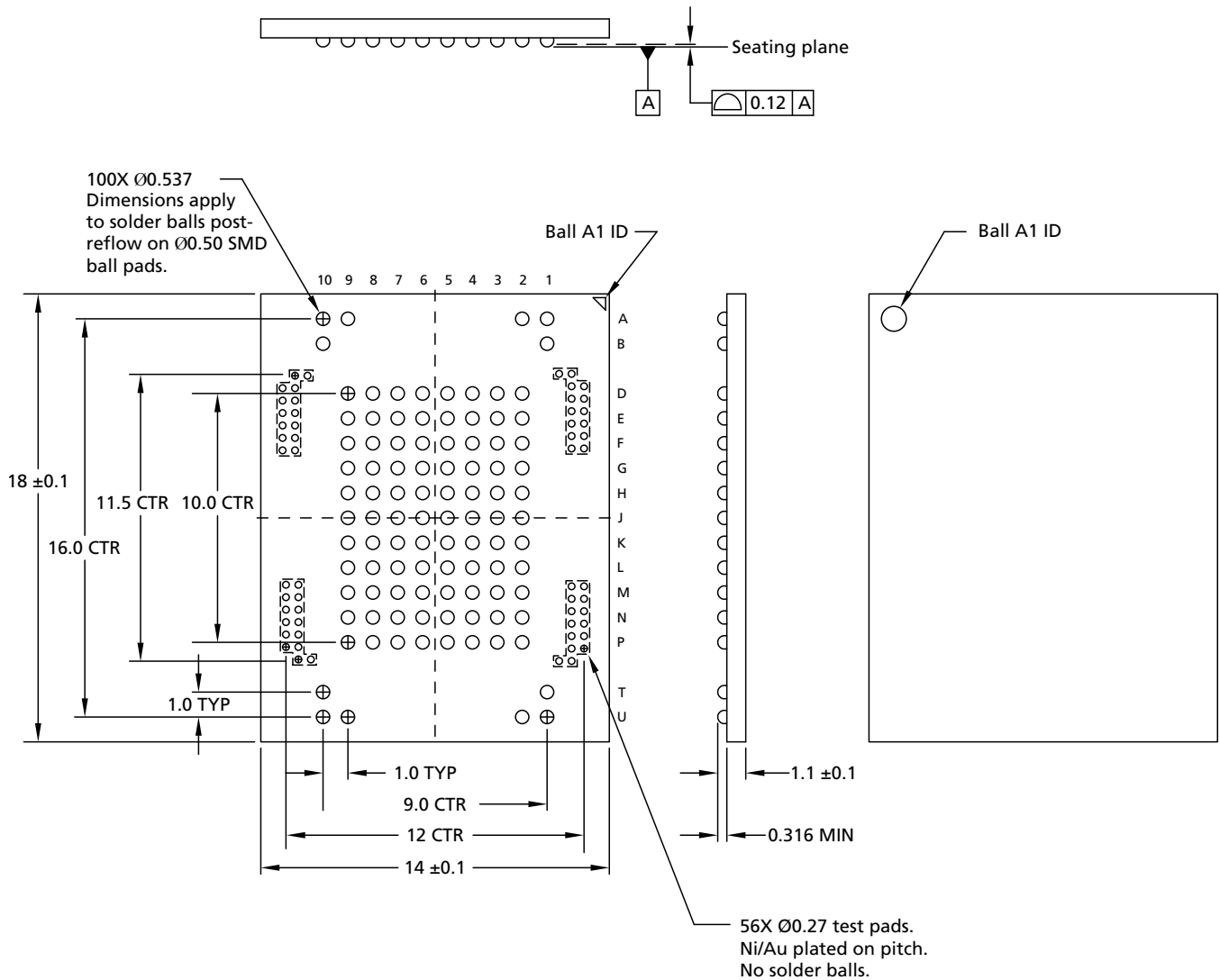

- Notes: 1. Dimensions are in millimeters
2. SAC302 Solder Ball

Architecture

Figure 8: e.MMC Functional Block Diagram

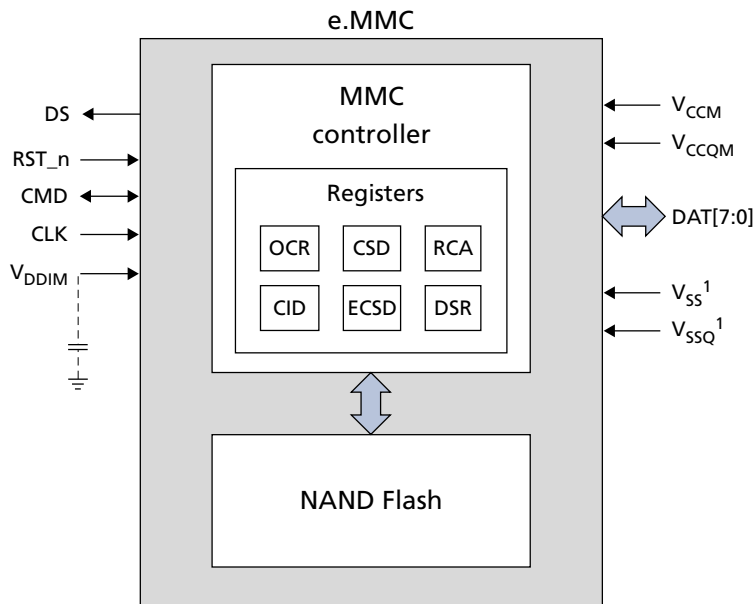

Note: 1. V_{SS} and V_{SSQ} are internally connected.

MMC Protocol Independent of NAND Flash Technology

The MMC specification defines the communication protocol between a host and a device. The protocol is independent of the NAND Flash features included in the device. The device has an intelligent on-board controller that manages the MMC communication protocol.

The controller also handles block management functions such as logical block allocation and wear leveling. These management functions require complex algorithms and depend entirely on NAND Flash technology (generation or memory cell type).

The device handles these management functions internally, making them invisible to the host processor.

Defect and Error Management

Micron e.MMC incorporates advanced technology for defect and error management. If a defective block is identified, the device completely replaces the defective block with one of the spare blocks. This process is invisible to the host and does not affect data space allocated for the user.

The device also includes a built-in error correction code (ECC) algorithm to ensure that data integrity is maintained.

To make the best use of these advanced technologies and ensure proper data loading and storage over the life of the device, the host must exercise the following precautions:

- Check the status after WRITE, READ, and ERASE operations.
- Avoid power-down during WRITE and ERASE operations.



OCR Register

The 32-bit operation conditions register (OCR) stores the voltage profile of the card and the access mode indication. In addition, this register includes a status information bit.

Table 5: OCR Parameters

OCR Bits	OCR Value	Description
[31]	1b (ready)/0b (busy) ¹	Device power-on status bit
[30:29]	10b	Sector mode
[28:24]	0 0000b	Reserved
[23:15]	1 1111 1111b	2.7–3.6V voltage range
[14:8]	000 0000b	2.0–2.7V voltage range
[7]	1b	1.70–1.95V voltage range
[6:0]	000 0000b	Reserved

Note: 1. OCR = C0FF8080h after the device has completed power-up.



CID Register

The card identification (CID) register is 128 bits wide. It contains the device identification information used during the card identification phase as required by e.MMC protocol. Each device is created with a unique identification number.

Table 6: CID Register Field Parameters

Name	Field	Width	CID Bits	CID Value
Manufacturer ID	MID	8	[127:120]	13h
Reserved	–	6	[119:114]	–
Card/BGA	CBX	2	[113:112]	01h
OEM/application ID	OID	8	[111:104]	–
Product name	PNM	48	[103:56]	–
Product revision	PRV	8	[55:48]	–
Product serial number	PSN	32	[47:16]	–
Manufacturing date	MDT	8	[15:8]	–
CRC7 checksum	CRC	7	[7:1]	–
Not used; always 1	–	1	[0]	–



CSD Register

The card-specific data (CSD) register provides information about accessing the device contents. The CSD register defines the data format, error correction type, maximum data access time, and data transfer speed, as well as whether the DSR register can be used. The programmable part of the register (entries marked with W or E in the following table) can be changed by the PROGRAM_CSD (CMD27) command.

Table 7: CSD Register Field Parameters

Name	Field	Size (Bits)	Cell Type ¹	CSD Bits	CSD Value
CSD structure	CSD_STRUCTURE	2	R	[127:126]	3h
System specification version	SPEC_VERS	4	R	[125:122]	4h
Reserved ²	–	2	–	[121:120]	–
Data read access time 1	TAAC	8	R	[119:112]	4Fh
Data read access time 2 in CLK cycles (NSAC × 100)	NSAC	8	R	[111:104]	01h
Maximum bus clock frequency	TRAN_SPEED	8	R	[103:96]	32h
Card command classes	CCC	12	R	[95:84]	0F5h
Maximum read data block length	READ_BL_LEN	4	R	[83:80]	9h
Partial blocks for reads supported	READ_BL_PARTIAL	1	R	[79]	0h
Write block misalignment	WRITE_BLK_MISALIGN	1	R	[78]	0h
Read block misalignment	READ_BLK_MISALIGN	1	R	[77]	0h
DSR implemented	DSR_IMP	1	R	[76]	1h
Reserved	–	2	–	[75:74]	–
Device size	C_SIZE	12	R	[73:62]	FFFh
Maximum read current at V _{DD,min}	VDD_R_CURR_MIN	3	R	[61:59]	7h
Maximum read current at V _{DD,max}	VDD_R_CURR_MAX	3	R	[58:56]	7h
Maximum write current at V _{DD,min}	VDD_W_CURR_MIN	3	R	[55:53]	7h
Maximum write current at V _{DD,max}	VDD_W_CURR_MAX	3	R	[52:50]	7h
Device size multiplier	C_SIZE_MULT	3	R	[49:47]	7h
Erase group size	ERASE_GRP_SIZE	5	R	[46:42]	1Fh
Erase group size multiplier	ERASE_GRP_MULT	5	R	[41:37]	1Fh
Write protect group size	WP_GRP_SIZE	5	R	[36:32]	0Fh
Write protect group enable	WP_GRP_ENABLE	1	R	[31]	1h
Manufacturer default ECC	DEFAULT_ECC	2	R	[30:29]	0h
Write-speed factor	R2W_FACTOR	3	R	[28:26]	2h
Maximum write data block length	WRITE_BL_LEN	4	R	[25:22]	9h
Partial blocks for writes supported	WRITE_BL_PARTIAL	1	R	[21]	0h
Reserved	–	4	–	[20:17]	–
Content protection application	CONTENT_PROT_APP	1	R	[16]	0h
File-format group	FILE_FORMAT_GRP	1	R/W	[15]	0h
Copy flag (OTP)	COPY	1	R/W	[14]	0h

Table 7: CSD Register Field Parameters (Continued)

Name	Field	Size (Bits)	Cell Type ¹	CSD Bits	CSD Value
Permanent write protection	PERM_WRITE_PROTECT	1	R/W	[13]	0h
Temporary write protection	TMP_WRITE_PROTECT	1	R/W/E	[12]	0h
File format	FILE_FORMAT	2	R/W	[11:10]	0h
ECC	ECC	2	R/W/E	[9:8]	0h
CRC	CRC	7	R/W/E	[7:1]	-
Reserved	-	1	-	[0]	-

- Notes:
1. R = Read-only;
R/W = One-time programmable and readable;
R/W/E = Multiple writable with value kept after a power cycle, assertion of the RST_n signal, and any CMD0 reset, and readable
 2. Reserved bits should be read as 0.



ECSD Register

The 512-byte extended card-specific data (ECSD) register defines device properties and selected modes. The most significant 320 bytes are the properties segment. This segment defines device capabilities and cannot be modified by the host. The lower 192 bytes are the modes segment. The modes segment defines the configuration in which the device is working. The host can change the properties of modes segments using the SWITCH command.

Table 8: ECSD Register Field Parameters

Name	Field	Size (Bytes)	Cell Type ¹	ECSD Bytes	ECS1.7D Value
Properties Segment					
Reserved ²	–	6	–	[511:506]	–
Extended Security Commands Error	EXT_SECURITY_ERR	1	R	[505]	00h
Supported command sets	S_CMD_SET	1	R	[504]	01h
HPI features	HPI_FEATURES	1	R	[503]	01h
Background operations support	BKOPS_SUPPORT	1	R	[502]	01h
Max-packed read commands	MAX_PACKED_READS	1	R	[501]	3Fh
Max-packed write commands	MAX_PACKED_WRITES	1	R	[500]	3Fh
Data tag support	DATA_TAG_SUPPORT	1	R	[499]	01h
Tag unit size	TAG_UNIT_SIZE	1	R	[498]	03h
Tag resources size	TAG_RES_SIZE	1	R	[497]	00h
Context management capabilities	CONTEXT_CAPABILITIES	1	R	[496]	05h
Large unit size	LARGE_UNIT_SIZE_M1	1	R	[495]	07h
Extended partitions attribute support	EXT_SUPPORT	1	R	[494]	03h
Supported modes	SUPPORTED_MODES	1	R	[493]	03h
Field firmware update features	FFU_FEATURES	1	R	[492]	00h
Operation code timeout	OPERATION_CODE_TIMEOUT	1	R	[491]	00h
Field firmware update arguments	FFU_ARG	4	R	[490:487]	00h
Reserved	–	181	–	[486:306]	–
Number of firmware sectors correctly programmed	NUMBER_OF_FW_SECTORS_CORRECTLY_PROGRAMMED	4	R	[305:302]	00h
Device health report	VENDOR_PROPRIETARY_HEALTH_REPORT	32	R	[301:270]	00h
Device life time estimation type B	DEVICE_LIFE_TIME_EST_TYP_B	1	R	[269]	01h
Device life time estimation type A	DEVICE_LIFE_TIME_EST_TYP_A	1	R	[268]	01h
Pre-end of life information	PRE_EOL_INFO	1	R	[267]	01h
Optimal read size	OPTIMAL_READ_SIZE	1	R	[266]	01h
Optimal write size	OPTIMAL_WRITE_SIZE	1	R	[265]	08h
Optimal trim unit size	OPTIMAL_TRIM_UNIT_SIZE	1	R	[264]	01h
Device version	DEVICE_VERSION	2	R	[263:262]	00h

Table 8: ECSD Register Field Parameters (Continued)

Name	Field	Size (Bytes)	Cell Type ¹	ECSD Bytes	ECS1.7D Value	
Firmware version ³	FIRMWARE_VERSION	8	R	[261:254]	–	
Power class for 200 MHz, DDR at V _{CC} = 3.6V	PWR_CL_DDR_200_360	1	R	[253]	00h	
Cache size	CACHE_SIZE	4	R	[252:249]	00000400h	
Generic CMD6 timeout	GENERIC_CMD6_TIME	1	R	[248]	19h	
Power-off notification (long) timeout	POWER_OFF_LONG_TIME	1	R	[247]	FFh	
Background operations status	BKOPS_STATUS	1	R	[246]	00h	
Number of correctly programmed sectors	CORRECTLY_PROG_SECTORS_NUM	4	R	[245:242]	00000000h	
First initialization time after partitioning (first CMD1 to device ready)	INI_TIMEOUT_AP	1	R	[241]	64h	
Reserved	–	1	–	[240]	–	
Power class for 52 MHz, DDR at 3.6V	PWR_CL_DDR_52_360	1	R	[239]	00h	
Power class for 52 MHz, DDR at 1.95V	PWR_CL_DDR_52_195	1	R	[238]	00h	
Power class for 200 MHz at 1.95V	PWR_CL_200_195	1	R	[237]	40h	
Power class for 200 MHz, at 1.3V	PWR_CL_200_130	1	R	[236]	00h	
Minimum write performance for 8-bit at 52 MHz in DDR mode	MIN_PERF_DDR_W_8_52	1	R	[235]	00h	
Minimum read performance for 8-bit at 52 MHz in DDR mode	MIN_PERF_DDR_R_8_52	1	R	[234]	00h	
Reserved	–	1	–	[233]	–	
TRIM multiplier	TRIM_MULT	16GB	1	R	[232]	16h
		32GB	1	R	[232]	27h
		64GB	1	R	[232]	16h
Secure feature support	SEC_FEATURE_SUPPORT	1	R	[231]	55h	
Secure erase multiplier	SEC_ERASE_MULT	1	R	[230]	01h	
Secure trim multiplier	SEC_TRIM_MULT	1	R	[229]	01h	
Boot information	BOOT_INFO	1	R	[228]	07h	
Reserved	–	1	–	[227]	–	
Boot partition size	BOOT_SIZE_MULT	1	R	[226]	80h	
Access size	ACC_SIZE	16GB	1	R	[225]	08h
		32GB	1	R	[225]	09h
		64GB	1	R	[225]	09h
High-capacity erase unit size	HC_ERASE_GRP_SIZE	1	R	[224]	01h	
High-capacity erase timeout	ERASE_TIMEOUT_MULT	16GB	1	R	[223]	14h
		32GB	1	R	[223]	1Ah
		64GB	1	R	[223]	14h
Reliable write-sector count	REL_WR_SEC_C	1	R	[222]	01h	

Table 8: ECSD Register Field Parameters (Continued)

Name	Field	Size (Bytes)	Cell Type ¹	ECSD Bytes	ECS1.7D Value	
High-capacity write protect group size	HC_WP_GRP_SIZE	1	R	[221]	10h	
Sleep current (V_{CC})	S_C_VCC	1	R	[220]	06h	
Sleep current (V_{CCQ})	S_C_VCCQ	1	R	[219]	07h	
Production state awareness timeout	PRODUCTION_STATE_AWARENESS_TIMEOUT	1	R	[218]	14h	
Sleep/awake timeout	S_A_TIMEOUT	1	R	[217]	12h	
Sleep notification time	SLEEP_NOTIFICATION_TIME	1	R	[216]	0Fh	
Sector count	SEC_COUNT	16GB	4	R	[215:212]	01B80000h
		32GB	4	R	[215:212]	03700000h
		64GB	4	R	[215:212]	06E40000h
Reserved	–	1	–	[211]	–	
Minimum write performance for 8-bit at 52 MHz	MIN_PERF_W_8_52	1	R	[210]	08h	
Minimum read performance for 8-bit at 52 MHz	MIN_PERF_R_8_52	1	R	[209]	08h	
Minimum write performance for 8-bit at 26 MHz and 4-bit at 52 MHz	MIN_PERF_W_8_26_4_52	1	R	[208]	08h	
Minimum read performance for 8-bit at 26 MHz and 4-bit at 52 MHz	MIN_PERF_R_8_26_4_52	1	R	[207]	08h	
Minimum write performance for 4-bit at 26 MHz	MIN_PERF_W_4_26	1	R	[206]	08h	
Minimum read performance for 4-bit at 26 MHz	MIN_PERF_R_4_26	1	R	[205]	08h	
Reserved	–	1	–	[204]	–	
Power class for 26 MHz at 3.6V	PWR_CL_26_360	1	R	[203]	00h	
Power class for 52 MHz at 3.6V	PWR_CL_52_360	1	R	[202]	00h	
Power class for 26 MHz at 1.95V	PWR_CL_26_195	1	R	[201]	00h	
Power class for 52 MHz at 1.95V	PWR_CL_52_195	1	R	[200]	00h	
Partition switching timing	PARTITION_SWITCH_TIME	1	R	[199]	03h	
Out-of-interrupt busy timing	OUT_OF_INTERRUPT_TIME	1	R	[198]	0Ah	
I/O driver strength	DRIVER_STRENGTH	1	R	[197]	1Fh	
Card type	CARD_TYPE	1	R	[196]	57h	
Reserved	–	1	–	[195]	–	
CSD structure version	CSD_STRUCTURE	1	R	[194]	02h	
Reserved	–	1	–	[193]	–	
Extended CSD revision	EXT_CSD_REV	1	R	[192]	07h	
Modes Segment						
Command set	CMD_SET	1	R/W/E_P	[191]	00h	

Table 8: ECSD Register Field Parameters (Continued)

Name	Field	Size (Bytes)	Cell Type ¹	ECSD Bytes	ECS1.7D Value
Reserved	–	1	–	[190]	–
Command set revision	CMD_SET_REV	1	R	[189]	00h
Reserved	–	1	–	[188]	–
Power class	POWER_CLASS	1	R/W/E_P	[187]	00h
Reserved	–	1	–	[186]	–
High-speed interface timing	HS_TIMING	1	R/W/E_P	[185]	00h
Reserved	–	1	–	[184]	–
Bus width mode	BUS_WIDTH	1	W/E_P	[183]	00h
Reserved	–	1	–	[182]	–
Erased memory content	ERASED_MEM_CONT	1	R	[181]	00h
Reserved	–	1	–	[180]	–
Partition configuration	PARTITION_CONFIG	1	R/W/E, R/W/E_P	[179]	00h
Boot configuration protection	BOOT_CONFIG_PROT	1	R/W, R/W/C_P	[178]	00h
Boot bus width	BOOT_BUS_WIDTH	1	R/W/E	[177]	00h
Reserved	–	1	–	[176]	–
High-density erase group definition	ERASE_GROUP_DEF	1	R/W/E_P	[175]	00h
Boot write protection status registers	BOOT_WP_STATUS	1	R	[174]	00h
Boot area write protection register	BOOT_WP	1	R/W, R/W/C_P	[173]	00h
Reserved	–	1	–	[172]	–
User write protection register	USER_WP	1	R/W, R/W/C_P, R/W/E_P	[171]	00h
Reserved	–	1	–	[170]	–
Firmware configuration	FW_CONFIG	1	R/W	[169]	00h
RPMB size	RPMB_SIZE_MULT	1	R	[168]	01h
Write reliability setting register ⁴	WR_REL_SET	1	R/W	[167]	1Fh
Write reliability parameter register	WR_REL_PARAM	1	R	[166]	15h
SANITIZE START operation	SANITIZE_START	1	W/E_P	[165]	00h
Manually start background operations	BKOPS_START	1	W/E_P	[164]	00h
Enable background operations handshake	BKOPS_EN	1	R/W	[163]	00h
Hardware reset function	RST_n_FUNCTION	1	R/W	[162]	00h
HPI management	HPI_MGMT	1	R/W/E_P	[161]	00h
Partitioning support	PARTITIONING_SUPPORT	1	R	[160]	07h

Table 8: ECSD Register Field Parameters (Continued)

Name	Field	Size (Bytes)	Cell Type ¹	ECSD Bytes	ECS1.7D Value	
Maximum enhanced area size	MAX_ENH_SIZE_MULT	16GB	3	R	[159:157]	000370h
		32GB	3	R	[159:157]	0006E0h
		64GB	3	R	[159:157]	000DC8h
Partitions attribute	PARTITIONS_ATTRIBUTE	1	R/W	[156]	00h	
Partitioning setting	PARTITION_SETTING_COMPLETED	1	R/W	[155]	00h	
General-purpose partition size	GP_SIZE_MULT_GP3	12	R/W	[154:152]	000000h	
	GP_SIZE_MULT_GP2			[151:149]	000000h	
	GP_SIZE_MULT_GP1			[148:146]	000000h	
	GP_SIZE_MULT_GP0			[145:143]	000000h	
Enhanced user data area size	ENH_SIZE_MULT	3	R/W	[142:140]	000000h	
Enhanced user data start address	ENH_START_ADDR	4	R/W	[139:136]	00000000h	
Reserved	–	1	–	[135]	–	
Bad block management mode	SEC_BAD_BLK_MGMNT	1	R/W	[134]	00h	
Production state awareness	PRODUCTION_STATE_AWARENESS	1	R/W/E	[133]	00h	
Package case temperature is controlled	TCASE_SUPPORT	1	W/E_P	[132]	00h	
Periodic wake-up	PERIODIC_WAKEUP	1	R/W/E	[131]	00h	
Program CID/CSD in DDR mode support	PROGRAM_CID_CSD_DDR_SUPPORT	1	R	[130]	01h	
Reserved	–	2	–	[129:128]	–	
Vendor specific fields	VENDOR_SPECIFIC_FIELD	64	<vendor specific>	[127:64]	–	
Native sector size	NATIVE_SECTOR_SIZE	1	R	[63]	00h	
Sector size emulation	USE_NATIVE_SECTOR	1	R/W	[62]	00h	
Sector size	DATA_SECTOR_SIZE	1	R	[61]	00h	
1st initialization after disabling sector size emulation	INI_TIMEOUT_EMU	1	R	[60]	00h	
Class 6 commands control	CLASS_6_CTRL	1	R/W/E_P	[59]	00h	
Number of addressed group to be released	DYNCAP_NEEDED	1	R	[58]	00h	
Exception events control	EXCEPTION_EVENTS_CTRL	2	R/W/E_P	[57:56]	0000h	
Exception events status	EXCEPTION_EVENTS_STATUS	2	R	[55:54]	0000h	
Extended partitions attribute	EXT_PARTITIONS_ATTRIBUTE	2	R/W	[53:52]	0000h	
Context configuration	CONTEXT_CONF	15	R/W/E_P	[51:37]	00h	
Packed command status	PACKED_COMMAND_STATUS	1	R	[36]	00h	
Packed command failure index	PACKED_FAILURE_INDEX	1	R	[35]	00h	
Power-off notification	POWER_OFF_NOTIFICATION	1	R/W/E_P	[34]	00h	
Control to turn the cache on/off	CACHE_CTRL	1	R/W/E_P	[33]	00h	

Table 8: ECSD Register Field Parameters (Continued)

Name	Field	Size (Bytes)	Cell Type ¹	ECSD Bytes	ECS1.7D Value	
Flushing of the cache	FLUSH_CACHE	1	W/E_P	[32]	00h	
Reserved	–	1	–	[31]	–	
Mode configuration	MODE_CONFIG	1	R/W/E_P	[30]	00h	
Mode operation codes	MODE_OPERATION_CODES	1	W/E_P	[29]	00h	
Reserved	–	2	–	[28:27]	–	
Field firmware update status	FFU_STATUS	1	R	[26]	00h	
Pre-loading data size	PRE_LOADING_DATA_SIZE4	4	R/W/E_P	[25:22]	00h	
Maximum pre-loading data size	MAX_PRE_LOADING_DATA_SIZE	16GB	4	R	[21:18]	00DC0000h
		32GB	4	R	[21:18]	01B80000h
		64GB	4	R	[21:18]	03720000h
Product state awareness enablement	PRODUCT_STATE_AWARENESS_ENABLEMENT	1	R/W/E, R	[17]	01h	
Secure removal type	SECURE_REMOVAL_TYPE	1	R/W/E, R	[16]	00h	
Reserved	–	16	–	[15:0]	–	

- Notes:
1. R = Read-only;
R/W = One-time programmable and readable;
R/W/E = Multiple writable with the value kept after a power cycle, assertion of the RST_n signal, and any CMD0 reset, and readable;
R/W/C_P = Writable after the value is cleared by a power cycle and assertion of the RST_n signal (the value not cleared by CMD0 reset) and readable;
R/W/E_P = Multiple writable with the value reset after a power cycle, assertion of the RST_n signal, and any CMD0 reset, and readable;
W/E_P = Multiple writable with the value reset after power cycle, assertion of the RST_n signal, and any CMD0 reset, and not readable.
 2. Reserved bits should be read as 0.
 3. Firmware version not populated here for more general document application. For current firmware version, consult Micron local support.
 4. Micron has tested power failure under best-application knowledge conditions with positive results. Customers may request a dedicated test for their specific application condition. Micron set this register during factory test and used the one-time programming option.



DC Electrical Specifications – Device Power

The device current consumption for various device configurations is defined in the power class fields of the ECSD register.

V_{CC} is used for the NAND Flash device and its interface voltage; V_{CCQ} is used for the controller and the e.MMC interface voltage.

Figure 9: Device Power Diagram

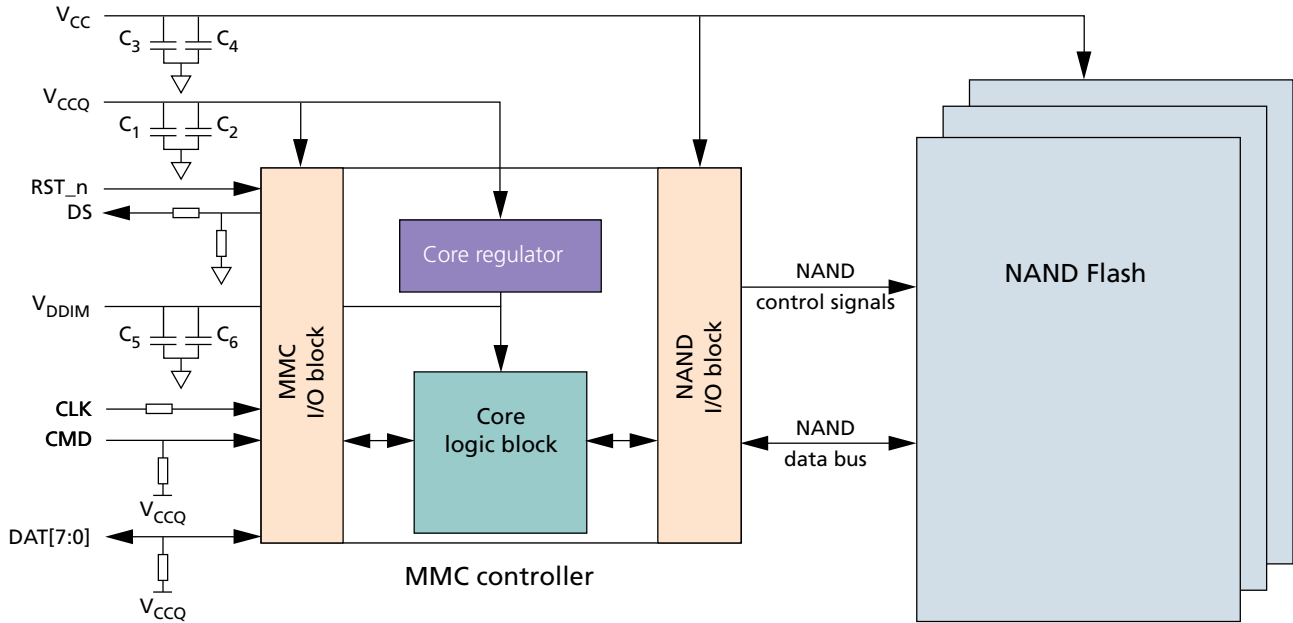

Table 9: Absolute Maximum Ratings

Parameters	Symbol	Min	Max	Unit
Voltage input	V_{IN}	-0.6	4.6	V
V_{CC} supply	V_{CC}	-0.6	4.6	V
V_{CCQ} supply	V_{CCQ}	-0.6	4.6	V
Storage temperature	T_{STG}	-40	85	°C

Note: 1. Voltage on any pin relative to V_{SS} .

Table 10: Capacitor and Resistance Specifications

Parameter	Symbol	Min	Max	Typ	Units	Notes
Pull-up resistance: CMD	R_CMD	4.7	50	10	kΩ	1
Pull-up resistance: DAT[7:0]	R_DAT	10	50	50	kΩ	1
Pull-up resistance: RST_n	R_RST_n	4.7	50	50	kΩ	2
CLK/CMD/DS/DAT[7:0] impedance		45	55	50	Ω	3
Serial resistance on CLK	SR_CLK	0	47	22	Ω	
Serial resistance on DS	SR_DS	0	47	22	Ω	4
Pull-down resistance: DS	R_DS	10	100	–	kΩ	
V _{CCQ} capacitor	C1	2.2	4.7	2.2	μF	5
	C2	0.1	0.22	0.1		
V _{CC} capacitor	C3	2.2	4.7	2.2	μF	6
	C4	0.1	0.22	0.1		
V _{DDIM} capacitor (C _{reg})	C5	1	4.7	1	μF	7
	C6	0.1	0.1	0.1		

- Notes:
- Used to prevent bus floating.
 - If host does not use H/W RESET (RST_n), pull-up resistance is not needed on RST_n line (Extended_CSD[162] = 00h).
 - Impedance match.
 - Recommended in order to compensate eventual impedance mismatch on the PCB.
 - The coupling capacitor should be connected with V_{CCQ} and V_{SSQ} as closely as possible.
 - The coupling capacitor should be connected with V_{CC} and V_{SS} as closely as possible.
 - The coupling capacitor should be connected with V_{DDIM} and V_{SS} as closely as possible.



Revision History

Rev. I – 08/18

- Added Important Notes and Warnings section for further clarification aligning to industry standards
- Corrected typo of package height tolerance in Package Dimensions for Package Codes: JP, CN
- Updated ECSD Register Field Parameters table

Rev. H – 10/17

- New MPNs added

Rev. G – 05/16

- Temperature and Data Strobe clarifications

Rev. F – 03/16

- Status update for 64GB device

Rev. E – 07/15

- Combined 153-ball and 100-ball packages
- Updated registers and performance data

Rev. D – 06/14

- Made package code and part number changes: MTFC16GAKAECN-4M IT, MTFC32GAKAECN-4M IT, and MTFC64GAKAEEY-4M IT

Rev. C – 06/14

- Updated the CID, CSD, and ECSD values
- Added new part numbers to the list on the first page

Rev. B – 04/14

- Added the "Absolute Maximum Ratings" table to the DC Electrical Specifications section

Rev. A – 01/14

- Initial release

8000 S. Federal Way, P.O. Box 6, Boise, ID 83707-0006, Tel: 208-368-4000
www.micron.com/products/support Sales inquiries: 800-932-4992
 Micron and the Micron logo are trademarks of Micron Technology, Inc.
 All other trademarks are the property of their respective owners.

This data sheet contains minimum and maximum limits specified over the power supply and temperature range set forth herein. Although considered final, these specifications are subject to change, as further product development and data characterization sometimes occur.